



Quality Insulation Installation (QII) Handbook For Installers and HERS Raters (2016 Energy Code)

Note: Structural Insulated Panels (SIPs) and Insulated Concrete Forms (ICFs) are not covered in this document – Refer to RA3.5 for these types of insulated assemblies.

© CalCERTS, Inc.
November 2017

Table of Contents

Contents

Table of Contents.....	2
Introduction.....	4
General Organization of this Document.....	5
Certificates (see RA3.5.X.1.3)	6
Certificates and Availability (see RA3.5.X.1.4).....	6
Coordination is Critical	6
Quality Insulation Installation Procedures	7
Purpose and Scope of these Procedures (see RA3.5.1).....	7
Definitions (see RA3.5.2).....	8
The Importance of Defining the Thermal Boundary	19
Special Requirements for Sealing Against Air Movement	22
Thermal Specifications.....	24
Thermal Specifications: Batts and Blankets (see RA3.5.3.1).....	24
Thermal Specifications: Loose fill (see RA3.5.4.1).....	25
Thermal Specifications: Rigid Board (see RA3.5.5.1)	26
Thermal Specifications: Spray-on Polyurethane Foam (see RA3.5.6.1).....	27
R-Value Measurement.....	30
R-Value Measurement: Batt (see RA3.5.3.1.2)	30
R-Value Measurement: Blown In (see RA3.5.4.1.2).....	30
R-Value Measurement: Rigid (see RA3.5.5.1.2).....	31
R-Value Measurement: SPF (see RA3.5.6.1.4)	31
General Requirements for Walls, Roof/Ceilings and Floors (see RA3.5.X.1.1).....	32
Walls, Roof/Ceilings and Floors: All Materials	32
Walls, Roof/Ceilings and Floors: Batt and Blanket	33
Walls, Roof/Ceilings and Floors: Loose Fill	33
Walls, Roof/Ceilings and Floors: Rigid Board	33
Walls, Roof/Ceilings and Floors: SPF	34
Specific Requirements for Wall Insulation (see RA3.5.X.2).....	35
Wall Insulation: All Materials	35
Wall Insulation: Batt and Blanket	35
Wall Insulation: Loose Fill	36

Wall Insulation: Rigid	36
Wall Insulation: SPF	37
Wall Insulation: Special Situations	37
Narrow-Framed Cavities (see RA3.5.X.2.1).....	37
Wall Insulation: Installation Prior to Exterior Sheathing or Lath (see RA3.5.X.2.2)	38
Rim Joists (see RA3.5.X.2.4)	39
Kneewalls, Skylight Shafts, and Gable Ends (see RA3.5.X.2.5).....	40
HVAC/Plumbing Closet (see RA3.5.X.2.6).....	42
Double Walls and Framed Bump-Outs (see RA3.5.X.2.7).....	43
Structural Bracing, Tie-downs, Steel Structural Framing (see RA3.5.X.2.8).....	43
Special Situations--Window and Door Headers (see RA3.5.X.2.9).....	44
Specific Requirements for Roof/Ceilings (see RA3.5.3.3).....	45
Roof Ceilings: Batt and Blanket	45
Roof Ceilings: Loose Fill	46
Roof Ceilings: Rigid	49
Roof Ceilings: SPF	49
Roof Ceilings: Special Situations	50
Enclosed Rafter Ceilings (see RA3.5.X.3.1).....	50
Attics and Cathedral Ceilings (see RA3.5.X.3.2)	51
HVAC Platform (see RA3.5.X.3.3).....	52
Attic Access (see RA3.5.X.3.4)	53
Specific Requirements for Raised Floors (see RA3.5.X.4).....	54
Homes with Conditioned Space Over Garage (see RA3.5.X.4.2).....	55
Homes with Unconditioned Space Over Garage (see RA3.5.X.4.3)	56
The “Cookie Cutter” Test.....	57
The QII Checklists.....	59
How to Read the Insulation Requirements on a CF1R-PRF-01	62

Introduction

Quality Insulation Installation (QII) is a procedure for ensuring that thermal insulation has been properly installed and that air sealing has been properly done in a home. It is based on industry standards (NAIMA) and similar to widely recognized national standards (RESNET and Energy Star), but it also has some unique requirements. Much of QII is simply installing insulation as the manufacturers intended.

QII is triggered when, using the performance compliance approach, the energy consultant/designer takes an optional compliance “credit” for QII. Actually, it is not a credit but the removal of a penalty that is otherwise applied to a typical house. This penalty was put in place in the 2005 Energy Code after a very extensive study showed that standard industry practice was to install



insulation very poorly. So poorly, in fact that the insulative properties were dramatically reduced. The study also found that the building envelope was almost never properly sealed, making the problem even worse.

In an effort to improve standard practice in the industry, the CEC developed the QII protocols. Rather than just requiring all homes to meet these requirements, the compliance modeling software takes a “guilty until proven innocent” approach and will automatically derate the insulation by as much as 13.3%, unless the user specifies QII. This then triggers the requirement for HERS verification.

When QII is required, it will be clearly indicated on the CF1R-PRF-01-E form and the appropriate CF2R Certificates of Installation and CF3R Certificates of Verification will be required to be completed and signed in the HERS registry.

It is worth noting that of all the HERS verified measures, QII has the highest fail rate. This is partly due to the fact that it requires very precise coordination between the Rater, the installer, and the general contractor/builder. It is also partly due to the fact that the industry still has a long way to go until standard practice is anything near what would pass QII. High turnover by installers is a known issue, as well. It is difficult to keep trained installers from moving on to more prestigious (and less itchy) construction jobs.

The current state of industry standard practice did not get this bad overnight. It evolved over time. One of the causes is the common use of paying installers for “piece work”. That is, paying them for each house completed, rather than paying them by the hour. This encourages installers to work faster and results in generally sloppy work. Passing the QII protocols requires that the installers slow down and exercise much more care and precision. Attention to detail is critical. Although it has been deemed cost-effective by the CEC, QII can have a significant impact on the cost of installation. Installing contractors need to be very aware of the requirements and should bid jobs accordingly.

Coordination between designers and the trades is critical. Passing QII is not completely the responsibility of the installer. Architects and framers are finding that they too have gotten sloppy on how a home’s thermal boundary and air barrier are defined and constructed. Framing details need to be clearly spelled out to show a continuous air barrier, for example: where a wall transitions from an exterior wall to an attic kneewall, or when floor joists extend to an attic.

General Organization of this Document

This document is essentially a simplified, yet enhanced version of the official QII protocols, Reference Appendices Section RA3.5. The text from that document has been simplified to eliminate repetitive sections and enhanced with diagrams, photos and explanation. If there is a conflict between this document and RA3.5, RA3.5 always takes precedence.

In this document, when you see an RA section number that has an “X” in it, such as RA3.5.X.2.1, this means that repetitive text from multiple sections in the Reference Appendices has been combined into a single section in this document. To determine the original RA3.5 section for a specific type of insulating material, replace the X with:

- “3” for Batt and Blanket
- “4” for Loose fill
- “5” for Rigid
- “6” for Spray-on Polyurethane Foam (SPF)

For example, notice how the text in these three sections is almost identical:

*Because so few **SIP** and **ICF** projects have been registered since the 2013 Energy Code went into effect (less than one half of one percent of all QII projects), we decided not to cover those insulation products in this document. They are not as prone to some of the most common installation issues and are covered well in sections RA3.5.7 and RA3.5.8.*

RA3.5.3

*These procedures detail the installation and inspection protocols necessary to qualify for Quality Insulation Installation (QII) of **batt and blanket** insulation. These procedures must be field verified before the building construction permit is finalized in order to claim QII energy compliance.*

RA3.5.4

*These procedures detail the installation and inspection protocols necessary to qualify for Quality Insulation Installation (QII) of **loose-fill** insulation. These procedures must be field verified before the building construction permit is finalized in order to claim QII energy compliance.*

RA3.5.5

*These procedures detail the installation and inspection protocols necessary to qualify for Quality Insulation Installation (QII) of **rigid board insulation sheathing material**. These procedures must be field verified before the building construction permit is finalized in order to claim QII energy compliance.*

In this document, it was all combined into:

RA3.5.X

These procedures detail the installation and inspection protocols necessary to qualify for Quality Insulation Installation (QII) of (all types of insulation). These procedures must be field verified before the building construction permit is finalized in order to claim QII energy compliance.

The Compliance Process: 1 – 2 – 3

In concept, the compliance process is quite simple.

- **Step 1 – Determine what is required.** This is done by the energy consultant and/or designer. The insulation requirements are documented on the CF1R-PRF-01, which must be consistent with the plans and specifications.
- **Step 2 – Install insulation that meets the requirements.** This is documented on the
 - CF2R-ENV-03 (a detailed list of the assemblies and products used)
 - CF2R-ENV-21 (a declaration by the installer that all applicable framing stage requirements of QII were met. See *QII Checklists*)
 - CF2R-ENV-22 (a declaration by the installer that all applicable ceiling and roof deck requirements of QII were met. See *QII Checklists*)
 - CF2R-ENV-23 (a declaration by the installer that all applicable insulation installation requirements of QII were met. See *QII Checklists*)
- **Step 3 – Verify what was installed.** This is documented on the: CF3R-ENV-21, 22 and 23, which correspond to the like-numbered CF2R forms but are filled out and signed by the HERS Rater.

In reality, without proper communication and coordination compliance can be quite complicated.

Certificates (see RA3.5.X.1.3)

Insulation Certificates of Installation (CF2Rs) signed by the insulation installer shall be completed in the HERS registry and state the installation is consistent with the CF1R, and plans and specifications for which the building permit was issued. The insulation installer shall also attach a product specification or data sheet for every insulation material used.

Certificates and Availability (see RA3.5.X.1.4)

The Insulation Certificates of Installation (CF2Rs), with insulation material labels or specification/data sheets attached, signed by the insulation installer, shall be available on the building site for each of the HERS Rater's verification inspections. The HERS Rater cannot verify compliance credit without these completed forms. This can be done digitally if the information is available in electronic format (PDF or scanned images).

Coordination is Critical

It is very important that the general contractor, the insulation installer and the HERS Rater work very closely together. Everyone needs to know exactly what is expected BEFORE the HERS Rater does the inspections. If there are any strange situations or if any of the requirements are unclear, they should be discussed in advance. Sometimes unique situations may require the involvement of CalCERTS Field Support or even Energy Commission staff.

The most difficult part of QII is probably the logistics of getting the HERS Rater out during a very small window of opportunity before the insulation gets covered up. **If insulation gets covered up prior to the HERS Rater seeing it, this is an automatic FAIL.** Your choices at that point are to expose the insulation (remove the sheetrock) or have the energy consultant re-run the energy calculations without the QII credit. This will require that other energy credits be substituted for the QII credit.

Quality Insulation Installation Procedures

Purpose and Scope of these Procedures (see RA3.5.1)

RA3.5 is a procedure for *verifying* the quality of insulation installation and air leakage control used in lowrise residential buildings. This procedure is to be followed by the insulation installer via CF2Rs and a qualified Home Energy Rating System (HERS) Rater must verify its conformance for meeting the requirements of Sections 150.1(c), and 110.7 of the Standards via CF3Rs.

The procedure applies to wood and metal construction of framed and non-framed envelope assemblies. Framed assemblies include wall stud cavities, roof/ceiling assemblies, and floors typically insulated with:

Section 110.7, in its entirety, reads, "All joints, penetrations and other openings in the building envelope that are potential sources of air leakage shall be caulked, gasketed, weather stripped, or otherwise sealed to limit infiltration and exfiltration."

- (1) batts of mineral fiber and mineral wool;
- (2) loose-fill materials of mineral fiber, mineral wool, and cellulose;
- (3) spray polyurethane foam; and,
- (4) rigid board sheathing materials.

Non-framed assemblies include wall, roof/ceiling, and floors constructed of

- (1) structural insulated panels (SIP)* and
- (2) insulated concrete forms (ICF)*.

Note 1: This procedure applies to the entire thermal envelope of the building. In many instances, residential homes will use several types of insulation material, even in the same framed assembly. Each insulation material and the integrity of air leakage control for the building's entire thermal envelope must be verified by the HERS Rater for the home to comply with the Standards.

Note 2: Structural bracing, tie-downs, and framing of steel or specialized framing used to meet structural requirements of the California Building Code (CBC) are allowed. These areas shall be called out on the building plans with diagrams and/or specific design drawings indicating the R-value amount and fastening method to be used. All structural framing areas shall be insulated in a manner that resists thermal bridging from the outside to the inside of the assembly separating conditioned from unconditioned space. The insulation and air barrier integrity shall be verified by the HERS Rater.

***Not covered in this Guide.**

Definitions (see RA3.5.2)

Continuous Air Barrier

A combination of interconnected materials and assemblies joined and sealed together to provide a continuous barrier to air leakage through the building envelope separating conditioned from unconditioned space, or adjoining conditioned spaces of different occupancies or uses. An air barrier is required in all thermal envelope assemblies to limit air movement between unconditioned/outside spaces and conditioned/inside spaces and must meet some very technical test requirements.

*Tip: The continuous air barrier will define the thermal boundary of a house. Designers and architects should decide very early in the design process **exactly** where the thermal boundary of a house is going to be. This seems trivial, but it really is not. Examples: bump-outs and fireplaces.*

If unsure of the materials, the completed building can be tested to demonstrate that the air leakage rate of the building envelope does not exceed 0.40 cfm/ft² at a pressure differential of 0.3 in w.g. (1.57 psf) (2.0 L/s.m² at 75 pa) in accordance with ASTM E779 or an equivalent approved method.

Note that this allows non-tested materials to be used as long as the house passes a blower door test with a special target of 0.40 cfm⁷⁵ for every square foot of conditioned floor area. Example: a 2100 square foot home would have a target of 840 cfm at 75 Pa.

Individual materials and assemblies of materials that can demonstrate compliance with the air barrier testing requirements must be installed according to the manufacturer's instructions and a HERS Rater shall verify the integrity of the installation. Below are example materials meeting

the air permeance testing performance levels above. Manufacturers of these and other product types must provide a specification or product data sheet showing compliance to the ASTM testing requirements to be considered as an air barrier.

- Plywood – minimum 3/8 inch
- Oriented strand board – minimum. 3/8 inches
- Extruded polystyrene insulation board – minimum. 1/2 inch
- Foil-back polyisocyanurate insulation board – minimum. 1/2 inch
- Extruded polystyrene insulation board – minimum 1/2 inch
- Foil backed urethane foam insulation (1 inch)
- Closed cell spray polyurethane foam with a minimum density of 2.0 pcf and a minimum thickness of 2.0 inches
- Open cell spray polyurethane foam with a minimum density of 0.4 to 1.5 pcf and a minimum thickness of 5 1/2 inches
- Exterior or interior gypsum board - minimum 1/2 inch
- Cement board - minimum 1/2 inch
- Built up roofing membrane
- Modified bituminous roof membrane
- Particleboard-minimum 1/2 inch
- Fully adhered single-ply roof membrane

- Portland cement/sand parge, or gypsum plaster minimum 5/8 inch
- Cast-in-place and precast concrete
- Fully grouted uninsulated and insulated concrete block masonry
- Sheet steel or aluminum

Air-tight

Limiting the passage of air either in or out of the building envelope.

Note: Thermal envelope assemblies (such as wall assemblies) shall be built to minimize air movement. Air movement brings unconditioned air and moisture through or into the assembly. For these procedures, air-tight shall be defined as an assembly or air barrier with all openings caulked, or sealed with minimally expansive foam, or taping/sealing of adjoining surfaces of air barrier materials and assemblies.



Compression

Compacting of insulation in an assembly that results in elimination of the air pockets trapped in the material that gives the insulation its R-value per inch. Batt insulation should be “lofted” and loose-fill and spray foam material properly field applied to the manufacturer specified density to

achieve its full R-value. Limited compression is allowed at plumbing, vents, and other obstructions and in cavities of non-standard framing. **Compression of insulation in these situations by more than 50% is excessive and shall not be allowed.**

Note that R-value is proportional to thickness and that compression does affect R-Value. You cannot cram an R-19 batt into a 2x4 wall and expect it to still be R-19. When the compression is more than 50% it begins to significantly affect the R-value per inch because the fibers are closer together and conduct heat better.

2x4 Framing
3.5"
R-13 Batt
No Compr.
R-13



Odd Framing
3.0"
R-13 Batt
~15% Compr.
R-11



Odd Framing
1.5"
R-13 Batt
~57% Compr.
Not Allowed



2x6 Framing
5.5"
R-19 Batt
No Compr.
R-19

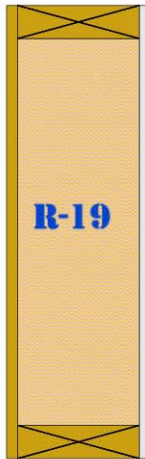

Odd Framing
5.0"
R-19 Batt
~9% Compr.
R-17



2x4 Framing
3.5"
R-19 Batt
~42% Compr.
R-12



Odd Framing
3.0"
R-19 Batt
~47% Compr.
R-10



Delaminated

Separation of the insulation's full thickness to facilitate its installation around or between obstructions. Batt and blanket insulation are often split or delaminated to fit around electrical wires and plumbing runs through a wall cavity. The delamination must ensure that the full thickness of the insulation is installed between the obstruction and the finish material covering the framing. For example, an electrical wire located one-third of the distance from the front of the cavity should have batt insulation delaminated so that two thirds of the batt is installed towards the outside wall surface and one-third is installed towards the inside wall surface from the wire.



Draft Stops

A material, device or construction installed to prevent the movement of air within open spaces of concealed areas of building components, such as crawl spaces, floor/ceiling assemblies, wall assemblies, roof/ceiling assemblies and attics. Note: Draft stops are important components of the air barrier and shall be airtight. Fire blocks constructed of porous insulation materials cannot serve as draft stops since they are not airtight.



This photo shows a draft stop cut from OSB to fit around two ducts going up through a large square chase. This is a smoke/fire requirement in many cases. Notice the open corners in the cut out holes where air can leak through (red arrows). These should be sealed with expansive foam or other approved material.

SPF can serve as a draft stop as long as it meets the minimum thickness required to be an air barrier.



Friction Fit

A means of attaching insulation within the framed cavity without the use of mechanical fasteners such that the material's full thickness in all directions is sufficient to maintain its installation integrity. In standard framing dimensions of 2x4' and 2x6" @ 16" oc and 24" oc, batt and blanket insulation materials have enough side-to-side frictional force to hold the insulation in place without any other means of attachment.

Note: Friction fitting of faced batt and blanket insulation, with or without an attachment flange, is allowed provided the insulation's installation integrity can be maintained.

Friction fitting may not be adequate in some cases, especially on walls where it may not get immediately covered up with an air barrier or sheathing material. Straps may be used as shown in this photo.



Gaps

Uninsulated areas at the edge of insulation where insulation is not in contact with framing members or other materials at the edge of the insulation. Gaps occur when insulation length and width is too short for the cavity. Gaps in insulation are avoidable and are not permitted.

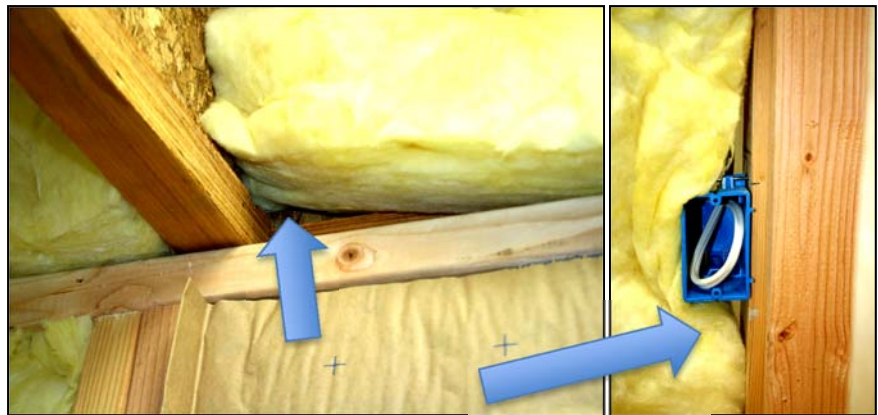

Hard Covers

Building materials, such as plywood or gypboard, which become part of the ceiling air barrier.

Note: Hard covers shall be installed above areas where there is a drop ceiling. For example, a home with 10ft ceilings may have an entry closet with a ceiling lowered to 8ft. In this case, a hard cover is installed at the 10ft level above the entry closet. Hard covers become part of the ceiling air barrier and shall be air-tight.

The Importance of Hard Covers

The first photo shows a typical dropped soffit inside a house that separates the kitchen from the family room. The second and third photos are from the attic looking down into this dropped soffit. You can see how the loose fill insulation has fallen down into the dropped area. This results in the upper portion of the dropped area being uninsulated. The diagram shows how a correctly installed hard cover would have prevented this.

Completely filling the dropped area with insulation is an inferior alternative. It creates substantially more surface area through which heat can conduct, plus the extra insulation needed is rarely accounted for and ends up stealing insulation from the rest of the attic.

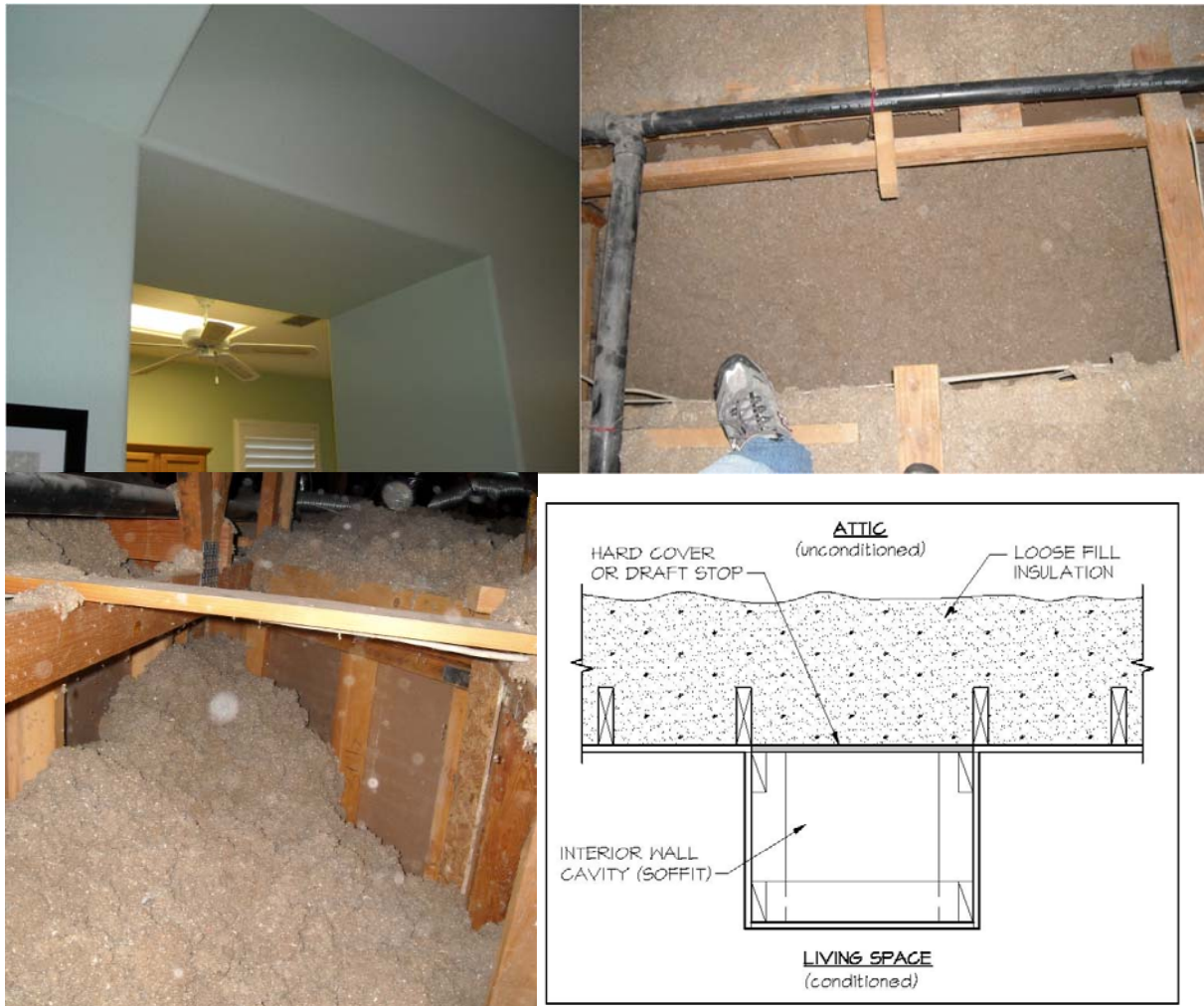

Inset Stapling

A method of attaching faced batt or blanket insulation to wood framing. The flange of the insulation facing is pushed inside the face of the framing member and stapled as opposed to stapling over the face of the studs, which can interfere with the gypboard. In windy areas installers often staple the flanges of faced batts to the sides of the stud in order to assure that the insulation remains in place until covered with drywall, particularly on the wall between the house and the garage where there isn't any exterior sheathing to help keep the insulation in place. The void created by the flange inset shall not extend more than two inches from the stud on each side.

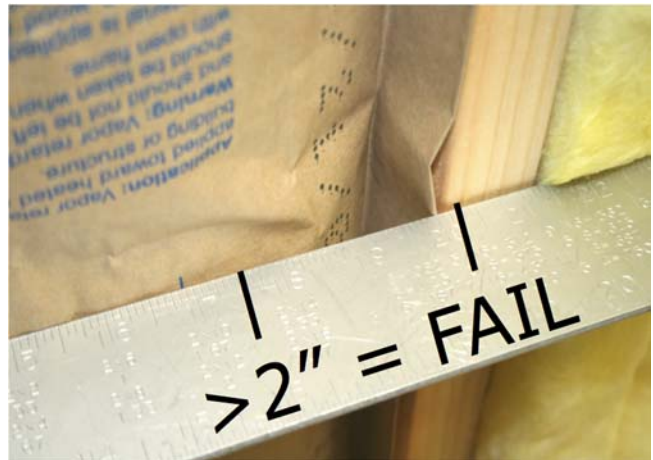

“Faced insulation” is a fiberglass batt with a paper glued to one face. This paper is called kraft paper and is impregnated with asphalt so that it performs as a vapor barrier (not an air barrier). Because it traps moisture, it is important that it not be installed on the side that gets cold in the winter because this could cause the moisture to condense on the paper, inside the wall. It should always be installed on the “warm in winter side.”

It is sometimes used purely as a support for insulation in walls that may not be covered for a while, such as the wall between the house and the garage which may have no backing until the sheetrock gets installed on both sides, unlike an exterior wall, which may have exterior siding holding up the insulation on one side. Stapling the paper to the studs will prevent this insulation from falling out. Even so, the paper needs to be installed to the garage side.

Minimally Expansive Foam Sealing Material

A single-component polyurethane foam system typically formulated in a handheld can or portable container to seal and fill construction gaps and crevasses, holes, and cracks without distorting adjacent framing. These materials are not used for insulation purposes, rather as agents for air sealing of gaps and crevasses that are too small to be insulated.

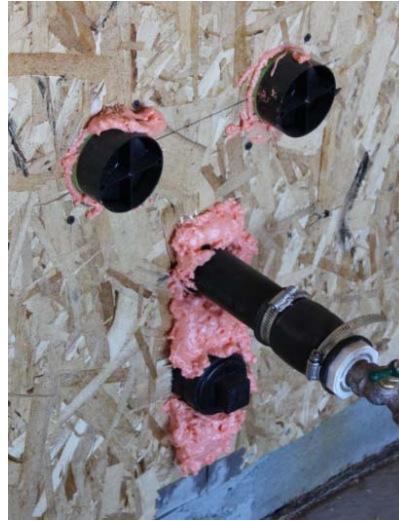

Net Free-Area

The net free-area of a vent cover is equal to the total vent opening less the interference to air flow caused by a screen or louver used for ventilation. Screened or louvered vent opening covers are typically marked by the manufacturer with the "net free-area." For example a 22.5 in. by 3.5 in. eave vent screen with a total area of 78.75 square inches may have a net free-area of only 45 square inches.

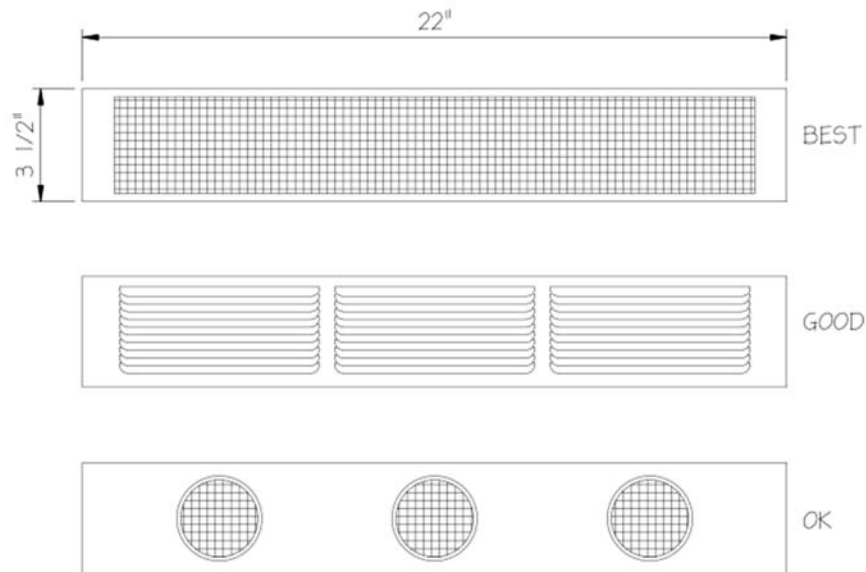

The Importance of Attic Ventilation

A great deal of research has gone into the benefits of preventing heat buildup in attics in the summer. Especially given that ducts are often located in the attic. The energy code encourages radiant barrier, insulation at the roof deck of a vented attic, and some means of mechanically ventilating an attic, such as whole house fans.

One of the most effective tools for removing heat from an attic is attic vents. Poor attic ventilation alone has been known to cause air conditioners to run at night even when it is cool outside, due to the trapped heat in the attic. There are a variety of types of vents: gable end, eyebrow, dormer, cloaked dormer, and eave vents. The latter being the most common, but also the most likely to be affected by improper installation of ceiling insulation and poor framing practices. It's not uncommon to look into a screened eave vent (top example above) and see nothing but insulation. While insulation is very poor at stopping airflow into or out of a house, it can be quite effective at reducing attic air movement.

HERS Raters will check to make sure that whatever the required vent area is at the vent is unobstructed all the way to the main volume of the attic. Obstructions by framing or improperly baffled insulation will result in a failed inspection. Designers are encouraged to install more ventilation than is allowed by code. The code minimum is actually not intended for the heat removal that we desire. More is generally better.

Voids & Air Spaces

An uninsulated space within an enclosed building assembly created where the assembly has been insulated by partial filling of the framed cavity. The partial fill results in an air space (void) between the insulation surface and the assembly's exterior or interior layers that form the assembly's air barrier.

Some voids are allowed with SPF only. See Thermal Specifications section.

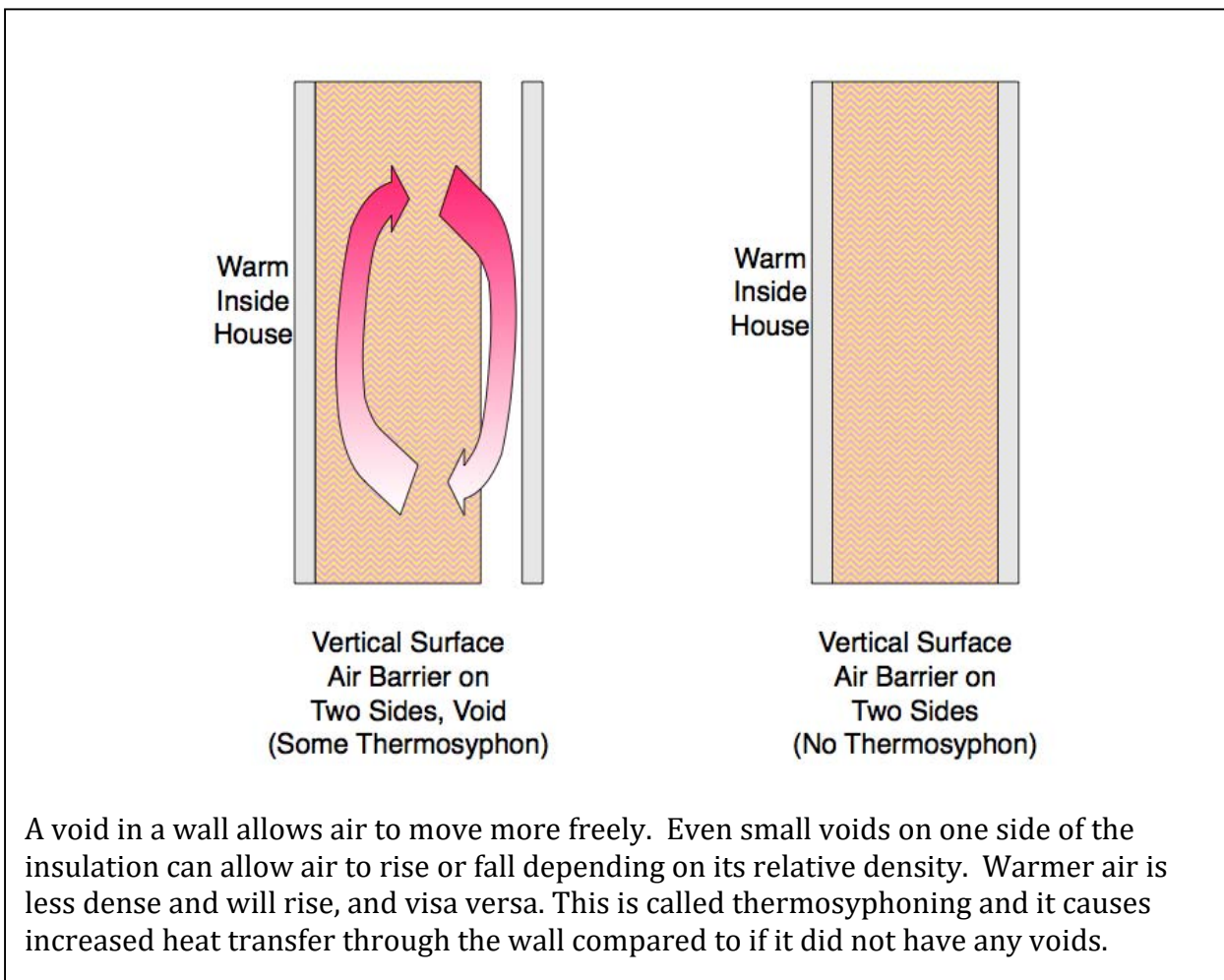
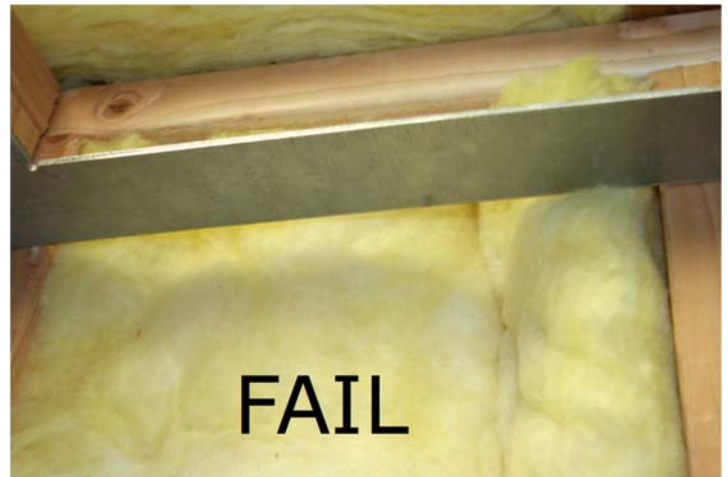

A void in a wall allows air to move more freely. Even small voids on one side of the insulation can allow air to rise or fall depending on its relative density. Warmer air is less dense and will rise, and visa versa. This is called thermosyphoning and it causes increased heat transfer through the wall compared to if it did not have any voids.

The Importance of Defining the Thermal Boundary

Coordination between trades is critical, as is the need for the designer of the house to really plan ahead on what exactly constitutes the thermal boundary. It can help to think of the thermal boundary as having two sides, an interior side and an exterior side. For ceilings, roofs, and rim joists, only one side needs to be in contact with an air barrier. With walls, **both** the interior and exterior surfaces need to be in *continuous* contact with an air barrier.

Consider the schematic section of this house:

It has two stories, an attached garage with attic above, a vented unconditioned attic above living space, a vented unconditioned crawlspace, and a fiberglass shower insert against an exterior wall (in this case a kneewall).

The interior and exterior surface of the conditioned boundaries are shown here in red.

Notice the **air barrier** must be continuous, without any breaks or interruptions where air could readily pass between conditioned and unconditioned spaces. The entire boundary is also properly insulated, except at normal framing members. These should be minimized where possible.

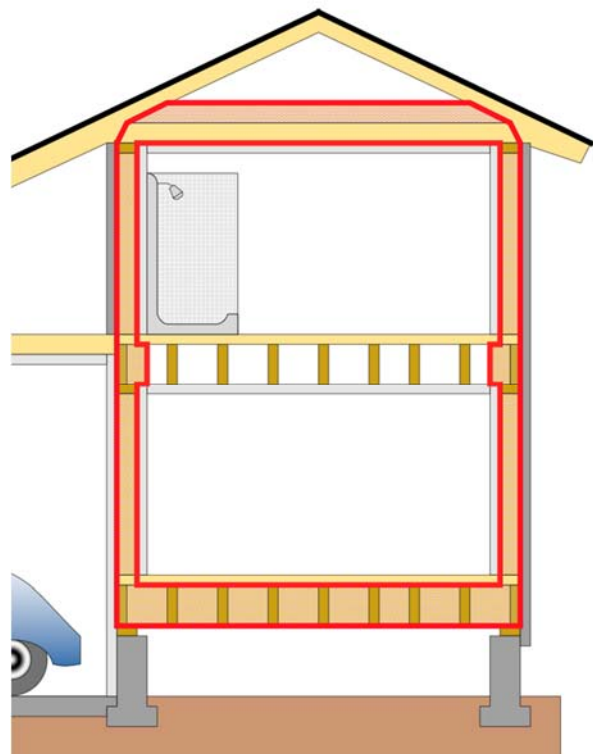
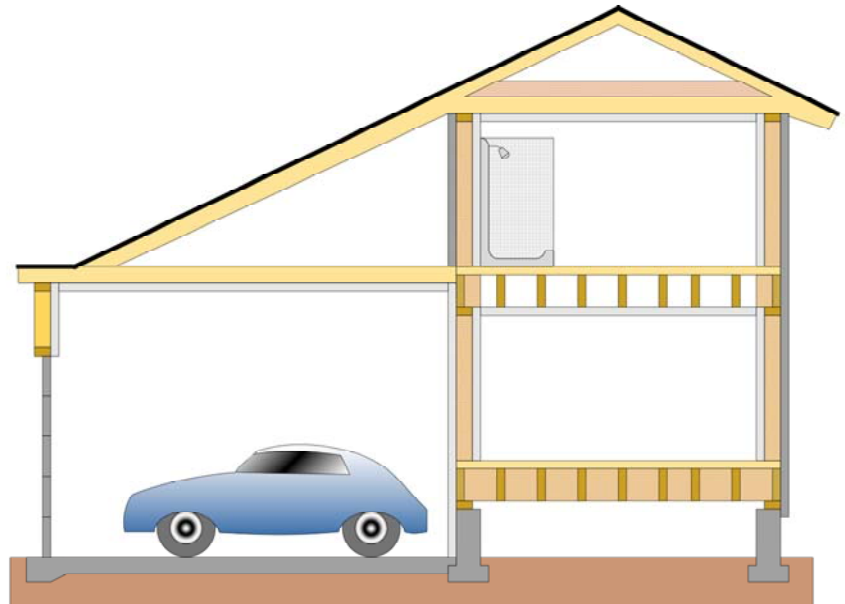

If the home had an unvented, conditioned attic, with insulation under the roof deck the conditioned boundary would be substantially different.

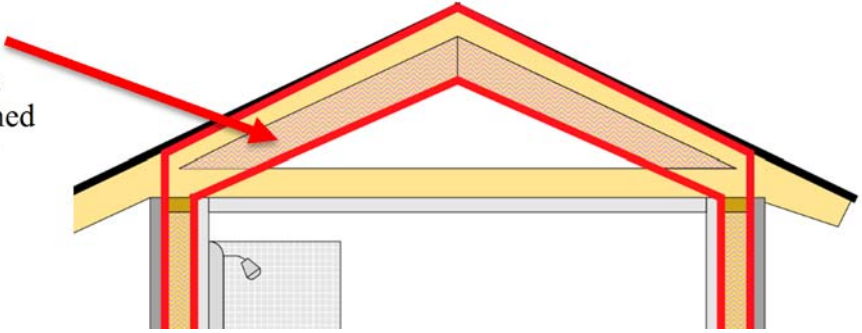

Similarly, if the home had an unvented, conditioned crawlspace, with insulation at the foundation walls the conditioned boundary would again be substantially different. Conditioned crawlspaces also require a plastic vapor barrier over any bare dirt.

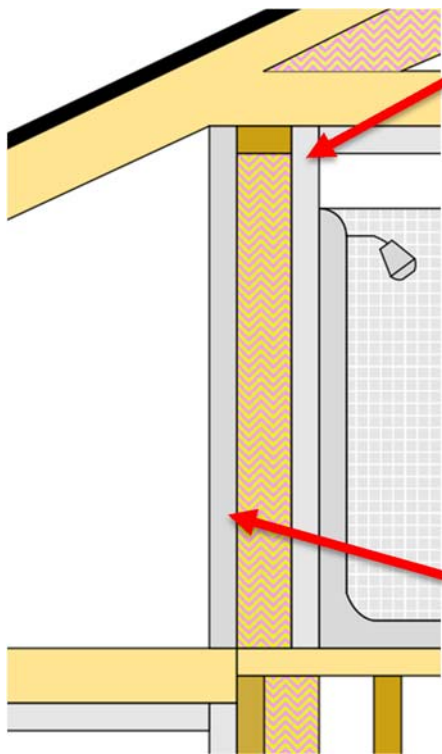
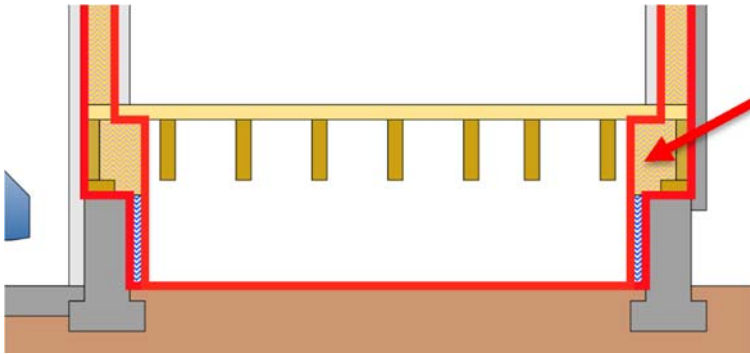

Note that the shower insert has an air barrier installed behind it. This is required by QII.

If there is no air barrier behind the shower, the interior surface of the air barrier would be the backside of the fiberglass shower insert. This would not meet the QII protocols.

Also note that there is an air barrier on the attic side of the kneewall. This can be a particular challenge that requires extra coordination.

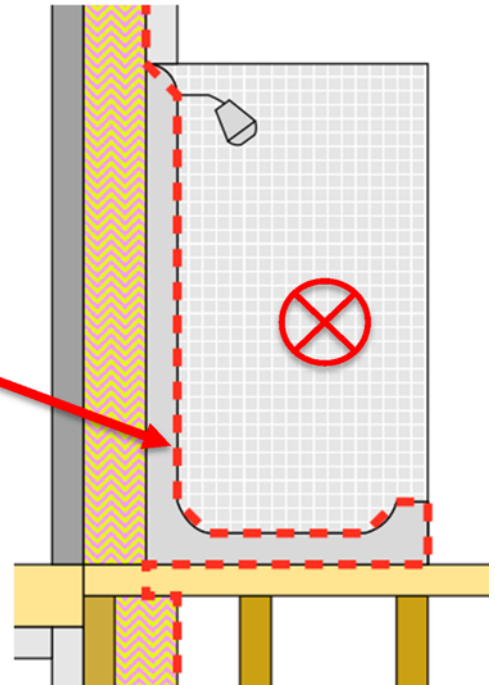

Frequently encountered challenges are exterior pop-outs for fireplaces. Historically, these have been treated like this, with the wall insulation stopping at the edge of the fireplace:

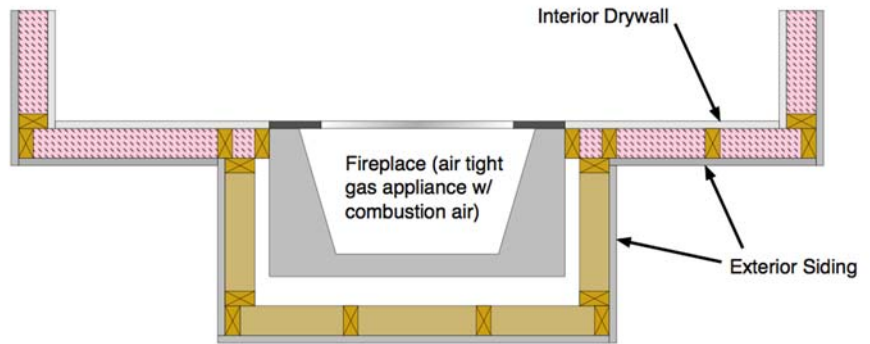

However, this is not acceptable practice to meet QII because it results in an inadequate thermal boundary.

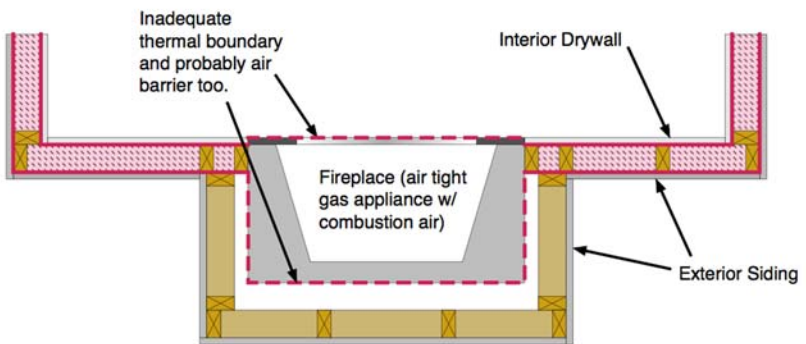

This approach would meet QII:

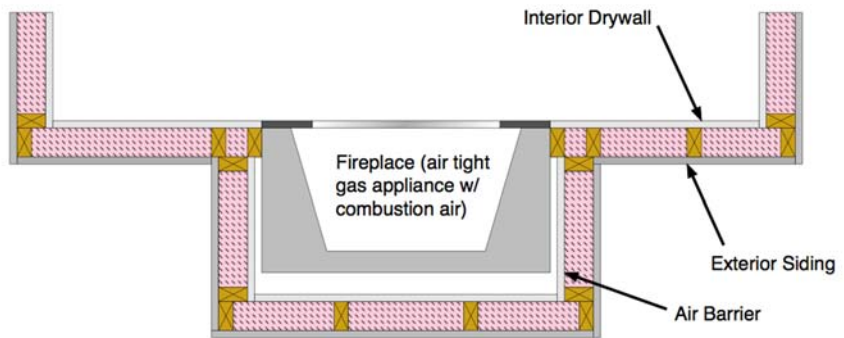

Note that at some point the pop-out will have a top, which must also be insulated. The flue will need to have an air tight flashing around it. See items D and E, next page.

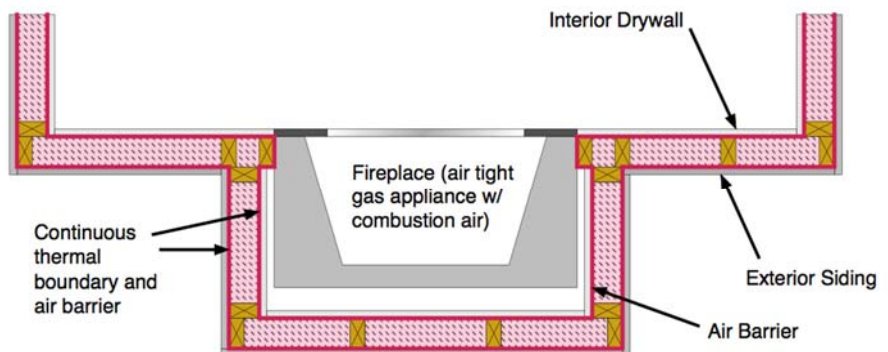

Special Requirements for Sealing Against Air Movement

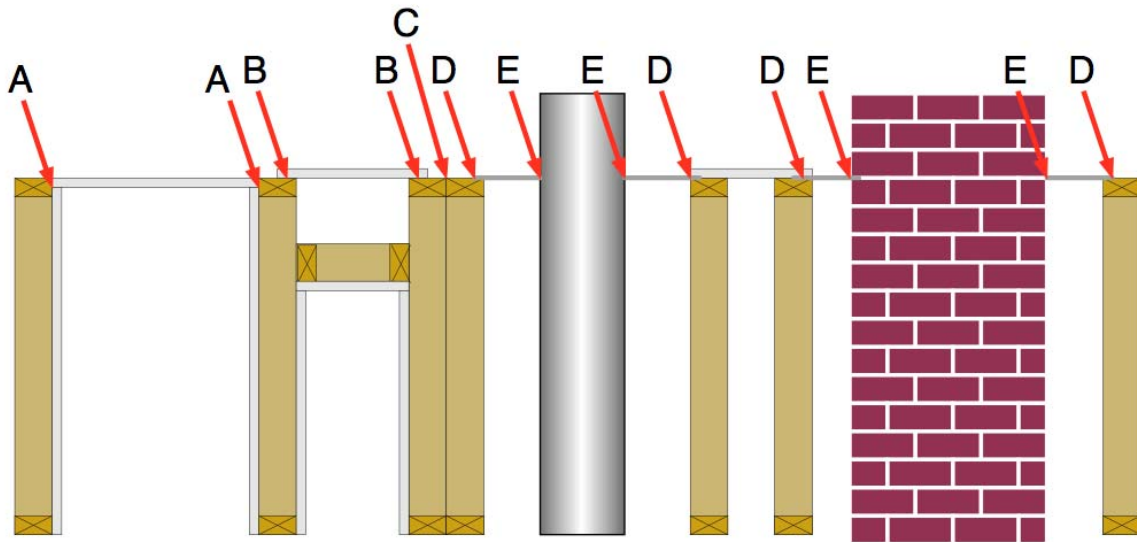

There must be a continuous air barrier at the ceiling level when there is unconditioned space above. Best practice is to also do this when there is a floor above.

- A. Seal where the sheet rock on the wall meets the top plate.
- B. Seal all hard covers to top plate.
- C. Seal any gaps between adjacent top plates of double walls.
- D. Seal metal flashing to top plates.
- E. Seal metal flashing to flues or chimneys with fire caulking as required by fire code.

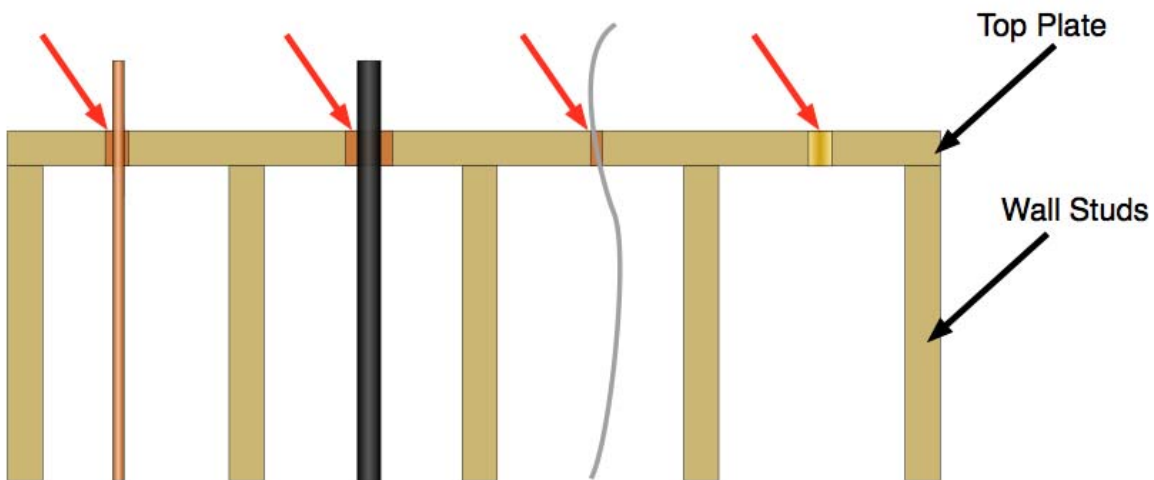

Seal all penetrations in top plates on interior and exterior walls for plumbing, vents, wires or any other holes when there is unconditioned space above. Best practice is to also do this when there is a floor above.

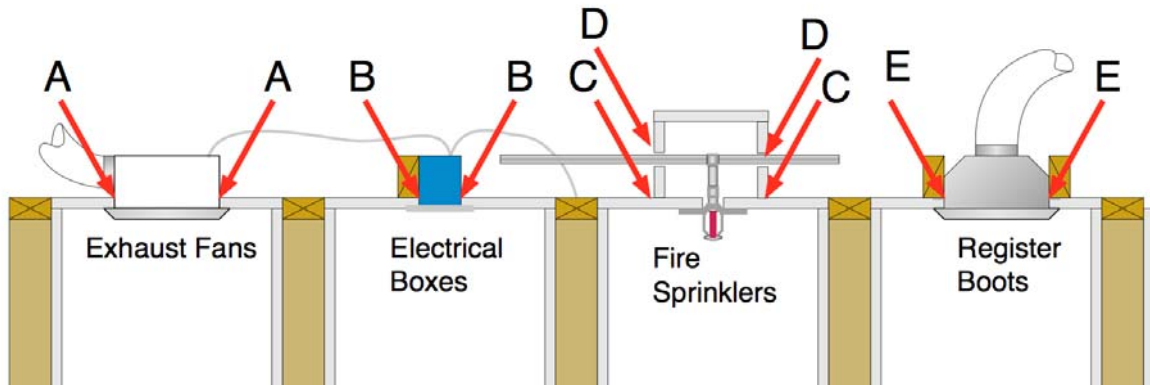

Seal all penetrations to the ceiling drywall when there is unconditioned space above. Best practice is to also do this when there is a floor above.

- A. Seal exhaust fan housing to drywall.
- B. Seal all electrical boxes that penetrate drywall to drywall.
- C. Seal all fire sprinklers to drywall.
- D. If sprinkler manufacturer does not allow sealing around the sprinkler head, an air tight box can be built over sprinkler. All penetrations in the box must be sealed as well as where box meets drywall.
- E. Seal around all HVAC supply and return register boots.

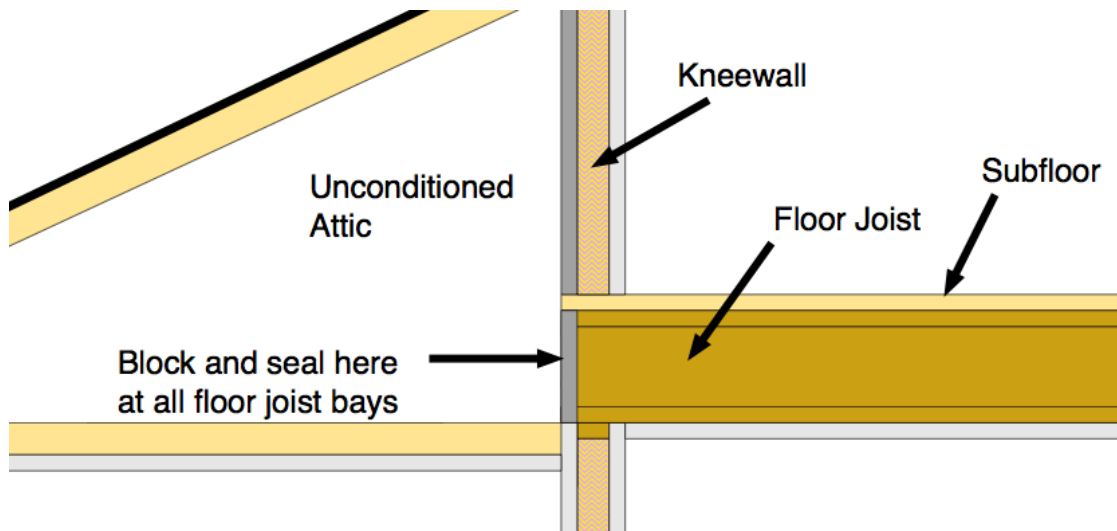

Where a kneewall sits on a subfloor the spaces between the floor joists must be blocked and sealed to prevent air from moving between the attic and floor joist bays.

Thermal Specifications

Thermal Specifications: **Batts and Blankets** (see RA3.5.3.1)

Definition: Batt and blanket insulation is made of mineral fiber and mineral wool -- either processed fiberglass, rock or slag wool -- and is used to insulate below floors, above ceilings, below roofs, and within walls.

This insulation type is manufactured in different widths, lengths, and thicknesses and is available with or without a facing. Faced batts and blanket insulation material is also available with or without an attachment flange. Specific product R-values are readily available from the manufacturer for the specific materials being installed and the R-value of the product is marked on the face of the product (faced or unfaced material). The installed insulation must meet the R-value stated on the compliance documentation.



Thermal Specifications: **Loose fill** (see RA3.5.4.1)

Definition: Loose-fill insulation includes loose fibers or fiber pellets that are blown into building cavities or attics using special equipment. Loose-fill insulations typically are produced using mineral fiber, mineral wool, or cellulose. They are installed in walls, floors, attics and below roofs using a dry-pack process or a moist-spray technique, and may include a netting material.

This insulation type is manufactured to be blown or sprayed into framed cavity walls, floors, and ceilings. It is installed with or without a net depending on the loose-fill type or in special installations where netting is required, such as below a roof deck or under floors. Its overall R-value is dependent on the installed density and installed thickness. Specific product R-values are readily available from the manufacturer for the specific materials being installed. R-value and coverage chart of the product is typically marked on the bag which the insulation was drawn from and from the manufacturer's product data sheet or product specification information. The installed insulation must meet the R-value stated on the compliance documentation.



Thermal Specifications: **Rigid Board** (see RA3.5.5.1)

Definition: Rigid board insulation sheathing is made from fiberglass, expanded polystyrene (EPS), extruded polystyrene (XPS, e.g., Styrofoam™), polyisocyanurate, or polyurethane. This type of insulation is used for above roof decks, exterior walls, cathedral ceilings, basement walls, as perimeter insulation at concrete slab edges, and to insulate special framing situations such as window and door headers, and around metal seismic bracing. Rigid board insulation may also be integral to exterior siding materials.

This insulation type is manufactured of different materials and is in sheet or board form. Rigid board insulation materials are typically used on the exterior side of framed wall assemblies and over the top of exterior roof decks. These products also may be used for special situations in rafter spaces of cathedral ceilings, floors, at floor rim joists, and within or on the outside of window and door headers. This insulation type may also be integral to exterior siding materials. Rigid board insulation material most often is used in conjunction with other insulation materials installed within the framed cavity. The R-value is dependent on the type of material and its thickness. Specific product R-values are readily available from the manufacturer for the specific materials being installed. R-value of the product is typically marked on the product. The installed insulation must meet the R-value stated on the compliance documentation.

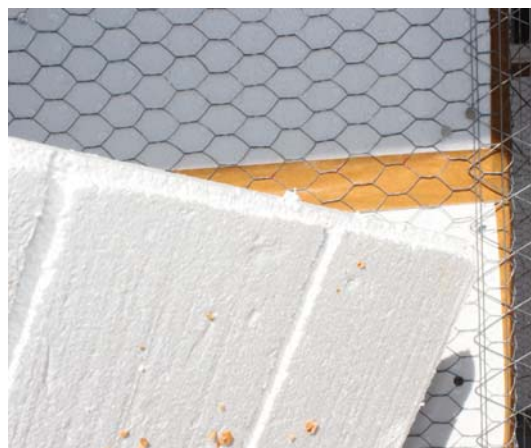

Thermal Specifications: **Spray-on Polyurethane Foam** (see RA3.5.6.1)

Definition: Spray-on Polyurethane Foam (SPF) is a two-part liquid foamed plastic (such as polyurethane or modified urethane) material formed by the reaction of an isocyanurate and a polyol that uses a blowing agent to develop a cellular structure when spray applied onto a substrate. SPF insulation is a two-component reactive system mixed at a spray gun or a single-component system that cures by exposure to humidity. The liquid is sprayed through a nozzle into wall, roof/ceiling, and floor cavities. SPF insulation can be formulated to have specific physical properties (i.e., density, compressive strength, fire resistance and R-value).

There are two basic types of SPF based on their density and cellular structure: Closed Cell and Open Cell. Closed Cell has a default R-value of R-5.8 per inch. Open Cell has a default R-value of R-3.6 per inch. Alternatively, the total R-value may be calculated based on the thickness of insulation multiplied by the "tested R-value per inch" as listed in the Table of R-values or R-value Chart from the manufacturer.



These photos show SPF being installed and the trailer or truck-mounted equipment needed to properly apply it.

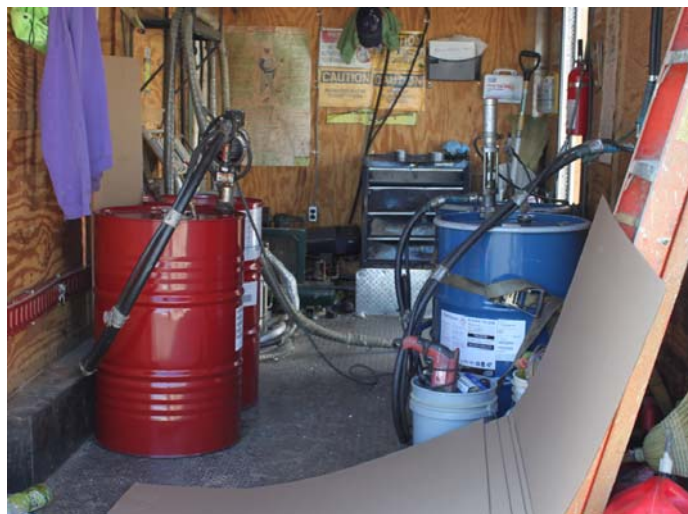

Thermal Specifications: Closed Cell SPF - ccSPF (see RA3.5.6.1.1)

Definition: A spray applied polyurethane foam insulation having a closed cellular structure resulting in an installed nominal density of **1.5** to less than **2.5** pounds per cubic foot (pcf).

R-value: The total R-value shall be calculated based on the nominal required thickness of the insulation multiplied by a thermal resistivity of **5.8** per inch. The R-value of ccSPF insulation shall meet or exceed the installed thickness specified in Table 3.5-1 below.

The R-value of the installed insulation shall be based on the verified thickness at an R-value of **5.8** per inch unless an Evaluation Service Report (ESR) is provided with compliance documentation that verifies use of other values (see previous discussion).

Nominal Thickness: ccSPF sprayed into framed cavities or on flat surfaces will expand with variable thicknesses, visibly appearing as undulations on the surface of the insulation. The average thickness of the foam insulation must meet or exceed the required R-value. Depressions in the foam insulation's surface shall not be greater than **1/2-inch** (less than) the required thickness at any given point of the surface area being insulated.

Filling of Framed Assemblies: ccSPF insulation is not required to fill the cavities of framed assemblies provided the installed thickness of insulation conforms to compliance documentation and that the bottom and top plates of vertical framing and both ends of horizontal framing, including band and rim joists, are sprayed to completely fill the cavity adjacent to and in contact with the framing to a distance of **2.0** inches away from the framing for ccSPF insulation, or filled to the thickness meeting ASTM testing as an air barrier.

Air Barrier: ccSPF installed as an air barrier shall be a minimum of **2.0** inches in thickness; alternatively, ccSPF insulation shall be installed at a thickness that meets an air permeance no greater than 0.02 L/s-m² at 75 Pa pressure differential when tested in accordance to ASTM E2178 or ASTM E283.

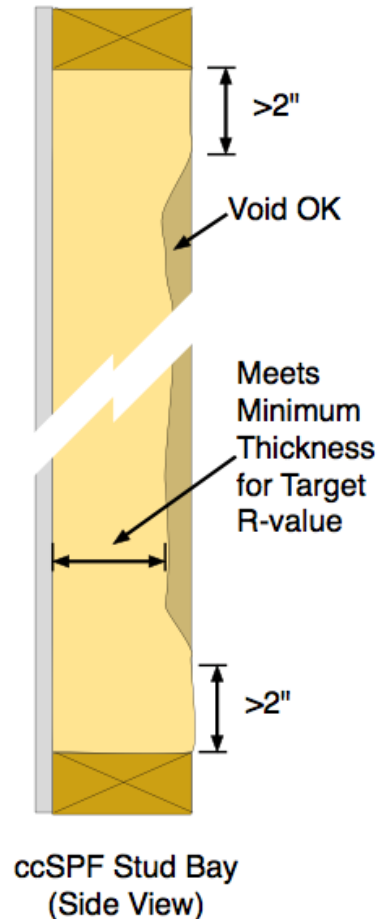

Table RA3.5-1-CC: Required Thickness of ccSPF Insulation to Achieve Specified R-values

Equivalent R-Values for SPF insulation	R-11	R-13	R-15	R-19	R-21	R-22	R-25	R-30	R-38
Required thickness of ccSPF insulation @ R5.8/inch	2.00"	2.25"	2.75"	3.5"	3.75"	4.00"	4.50"	5.25"	6.75"

Thermal Specifications: Open Cell SPF - ocSPF (see RA3.5.6.1.2)

A spray applied polyurethane foam insulation having an open cellular structure resulting in an installed nominal density of **0.4** to less than **1.5** pounds per cubic foot (pcf).

R-value: The total R-value shall be calculated based on the nominal required thickness of the insulation multiplied by a thermal resistivity of **3.6** per inch. The R-value of ocSPF insulation shall meet or exceed the installed thickness specified in Table 3.5-1 below.

The R-value of the installed insulation shall be based on the verified thickness at an R-value of **3.6** per inch unless an ESR is provided with compliance documentation that verifies use of other values.

Nominal Thickness: ocSPF sprayed into framed cavities or on flat surfaces will expand with variable thicknesses, visibly appearing as undulations on the surface of the insulation. The average thickness of the foam insulation must meet or exceed the required R-value. Depressions in the foam insulation surface shall not be greater than **1-inch** of the required thickness provided these depressions do not exceed 10% of the surface area being insulated.

Filling of Framed Assemblies: ocSPF insulation shall completely fill cavities of 2x4 inch framing or less. Cavities greater than 2x4 inch framing dimensions may be filled to the thickness that meets the required R-value used for compliance provided that the bottom and top plates of vertical framing and both ends of horizontal framing, including band and rim joists, are sprayed to completely fill the cavity adjacent to and in contact with the framing to a distance of **5.5** inches away from the framing for ocSPF insulation, or filled to the thickness meeting ASTM testing as an air barrier.

Air Barrier: ocSPF installed as an air barrier shall be a minimum of **5.5** inches in thickness; alternatively, ocSPF insulation shall be installed at a thickness that meets an air permeance no greater than 0.02 L/s-m² at 75 Pa pressure differential when tested in accordance to ASTM E2178 or ASTM E283.

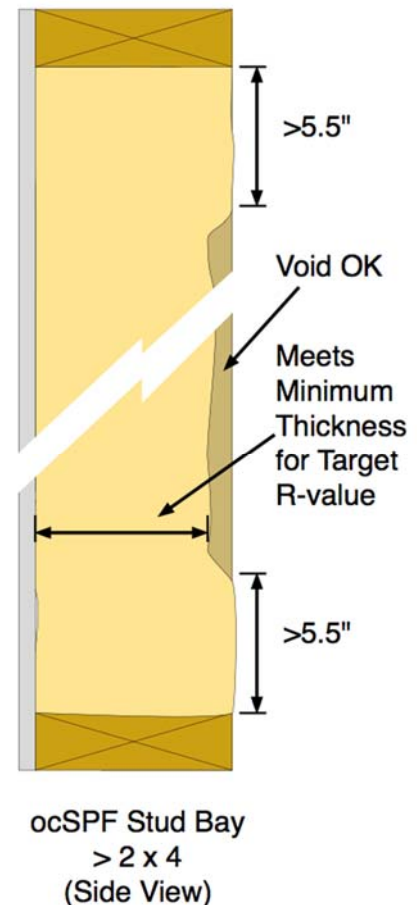

Table RA3.5-1-OC: Required of ocSPF Insulation to Achieve Specified R-values

Equivalent R-Values for SPF insulation	R-11	R-13	R-15	R-19	R-21	R-22	R-25	R-30	R-38
Required thickness of ocSPF insulation@ R3.6/inch	3.0"	3.5"	4.2"	5.3"	5.8"	6.1"	6.9'	8.3"	10.6"

R-Value Measurement

R-Value Measurement: **Batt** (see RA3.5.3.1.2)

The HERS Rater shall verify the installed thickness of insulation in all assemblies and locations on walls, roof/ceilings, and floors, and to ensure that insulation levels and installation integrity meet the R-value specified on the Certificate of Compliance, and all other required compliance documentation.

R-Value Measurement: **Blown In** (see RA3.5.4.1.2)

The HERS Rater shall measure the installed thickness (inches) and density (lbs per square feet) of insulation on walls, roof/ceilings and floors to ensure minimum thickness levels and the installed density meets the R-value specified on the Certificate of Compliance, and all other required compliance documentation. For walls, measurement areas shall include low and high areas of the insulated assembly and the HERS Rater shall verify density measurements are consistent with the manufacturer's coverage chart. (See "Cookie Cutter Test" section at end of this document.)

R13 to R60

Nature Blend™ Loose Fill Formula Coverage Chart for Thermal Acoustical Application

R-Value @ 75°F	Initial Installed Thickness (Inches)	Minimum Settled Thickness (Inches)	No Joists (Sin ajuste por armazon)			2" x 6", 16" O.C.		
			Bags Per 1000 Sq. Ft.	Net Coverage Sq. Ft. Per Bag	Minimum Weight Per Sq. Ft.	Bags Per 1000 Sq. Ft.	Net Coverage Sq. Ft. Per Bag	Minimum Weight Per Sq. Ft.
R-Value @ 75°F	Espesor despues de asentamiento en separaciones y vacios	Aislamiento instalado no debe ser menos de	Cantidad minima de bolsas por 100 metros cuadrados	Maximo de Recubrimiento Neto	Pesos minimo por metros cuadrados	Cantidad minima de bolsas por 100 metros cuadrados	Maximo de Recubrimiento Neto	Pesos minimo por metros cuadrados
13	4.4	4.0	17.4	57.5	0.38	15.8	63.5	0.35
19	6.1	5.5	27.9	35.8	0.61	25.3	39.6	0.56
22	6.9	6.2	33.2	30.1	0.73	30.5	32.8	0.67
25	7.8	7.0	38.6	25.9	0.85	35.8	28.0	0.79
30	9.2	8.3	47.6	21.0	1.05	44.6	22.4	0.98
38	11.4	10.3	62.0	16.1	1.36	58.9	17.0	1.30
49	14.6	13.1	82.0	12.2	1.80	78.7	12.7	1.73
60	17.7	15.9	101.9	9.8	2.24	98.6	10.1	2.17

R-Value Measurement: **Rigid** (see RA3.5.5.1.2)

The HERS Raters shall verify the installed thickness of insulation in all assemblies and locations on walls, roof/ceilings, and floors, and to ensure that insulation levels and installation integrity meet the R-value specified on the Certificate of Compliance, and all other required compliance documentation. Different products will have different R-values per inch.

Note: Rigid insulation is sometimes referred to as “sheathing” or “continuous” insulation on the CFIR-PRF-01. Sometimes the surface will be named something like “R-15+4 wall”, meaning that there is R-15 in the cavity (between studs) and R-4 continuous insulation, usually on the exterior of the wall. It is important to realize that the name of a surface on the CFIR is just a text field and has no impact on the simulation results. You have to look at the detailed description and U-factor to determine what is actually required. In other words, a surface mis-named “R-13 wall” may have actually been modeled as an R-15+4 wall. This can easily cause a lot of confusion.



R-Value Measurement: **SPF** (see RA3.5.6.1.4)

The HERS Rater shall measure the installed thickness of insulation in at least 6 random locations on walls, roof/ceilings and floors (i.e., 6 measurements per opaque surface type: wall, roof/ceiling or floor) to ensure minimum thickness levels necessary to meet the R-value specified on the Certificate of Compliance, and all other required compliance documentation. Measurement areas shall include low and high areas of the SPF insulated surface.

Probes are typically used for inspection and measurement of installed thickness of SPF insulation. The insulation thickness shall be verified by using a probe, gauge or device capable of measuring the installed thickness of insulation. A pointed measurement probe or other gauge or device, capable of penetrating the full thickness of the insulation, shall be used having measurements marked by at least one-eighth inch increments. Insulation thickness measurement probes and gauges or devices shall be accurate to within $\pm 1/8$ inch and shall be designed and used in a manner to cause minimal damage to the insulation. A metal skewer and ruler are commonly used.

General Requirements for Walls, Roof/Ceilings and Floors (see RA3.5.X.1.1)

Walls, Roof/Ceilings and Floors: All Materials

- Materials shall comply with, and be installed in conformance with, all applicable building codes for building.
- Materials shall meet California Quality Standards for Insulating Material, Title 24, Part 12, Chapter 4, Article 3, listed in the California Department of Consumer Affairs Consumer Guide and Directory of Certified Insulating Materials.
- Materials shall comply with flame spread rating and smoke density requirements of Chapter 26 and Section 720 of the Title 24, Part 2: all installations with exposed facings must use fire retardant facings which have been tested and certified not to exceed a flame spread of 25 and a smoke development rating of 450. Insulation facings that do not touch a ceiling, wall, or floor surface, and faced batts on the undersides of roofs with an air space between the ceiling and facing are considered exposed applications.
- Materials shall be installed according to manufacturer specifications and instructions.
- Hard covers or draft stops shall be placed over all drop ceiling areas and interior wall cavities to keep insulation in place and stop air movement. If hard covers or draft stops are missing or incomplete, they shall be completed before insulation is installed. (See example in Definitions section)
- Required eave ventilation shall not be obstructed - the net free-ventilation area of the eave vent shall be maintained. (See example in *Definitions* section)
- Eave vent baffles shall be installed to prevent air movement under or into the insulation material.

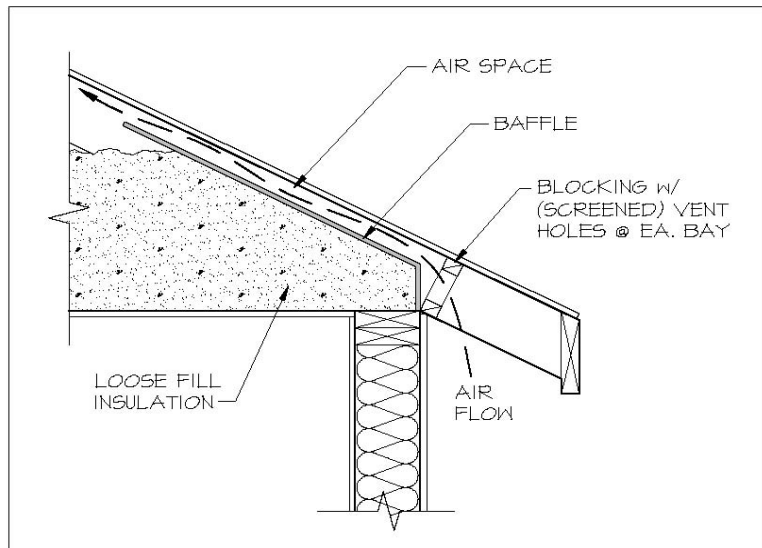

- Insulation (except SPF) shall cover all recessed lighting fixtures. All recessed light fixtures that penetrate the ceiling shall be listed for zero clearance insulation contact (IC), have a label that certifies it as airtight when tested to ASTM E283.

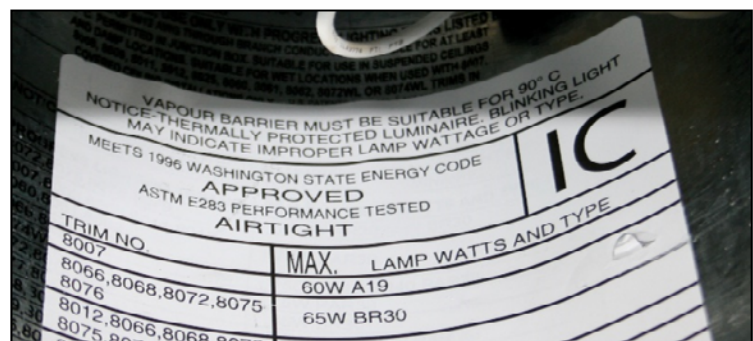

Walls, Roof/Ceilings and Floors: **Batt and Blanket**

- Batt and blanket insulation shall be correctly sized to fit snugly at the sides and ends. (aka, Six-sided Contact)
- Batt and blanket insulation shall be installed so that they will be in contact with the air barrier.
- Where necessary, batt and blanket insulation shall be cut to fit properly - there shall be no gaps, nor shall the insulation be doubled-over or compressed.
- When batt and blanket insulation are cut to fit a non-standard cavity, they shall be snugly fitted to fill the cavity without excessive compression.
- Batt and blanket insulation shall be cut to butt-fit around wiring and plumbing, or be split (delaminated) so that one layer can fit behind the wiring or plumbing, and one layer fit in front.
- For batts and blanket insulation that is taller than the trusses, full-width batts shall be used so that they expand to touch each other over the trusses.

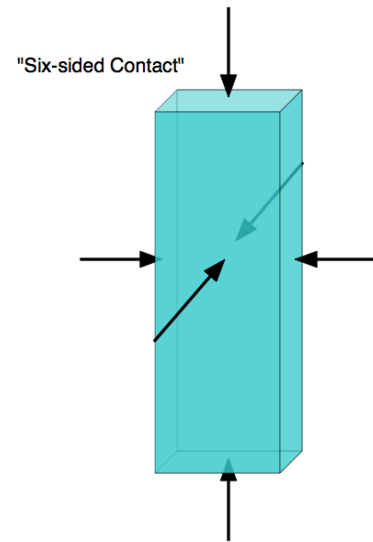

Walls, Roof/Ceilings and Floors: **Loose Fill**

- Loose-fill insulation must completely fill the framed cavity.
- Loose-fill insulation shall be installed so that they will be in contact with the air barrier.

Walls, Roof/Ceilings and Floors: **Rigid Board**

- Rigid board insulation shall be attached according to the manufacturer's specifications.
- Rigid board insulation may be used as the air barrier provided it has been tested to conform to the air barrier performance conditions of the Standards.

Walls, Roof/Ceilings and Floors: SPF

- The installer shall determine and the HERS Rater shall verify that the manufacturer's nominal insulation thickness has been installed and certified and that all requirements of the Certificate of Verification have been met.
- The installer shall determine and the HERS Rater shall verify that insulation is in substantial contact with the assembly air barrier. When SPF insulation is being used to provide air barrier control, the SPF insulation must cover and be in contact with the entire surface of the framing, filling the cavity to a distance away from the framing specified in "Filling of Framed Assemblies" above.
- SPF insulation shall be applied by SPF applicators trained and experienced in the use and maintenance of high-pressure, plural-component equipment. SPF applicators shall be certified by the SPF insulation manufacturer for the application of SPF insulation systems.
- SPF insulation shall be spray-applied to fully adhere to assembly framing, floor and ceiling, the joists, and other framing surfaces within the construction cavity. When multiple layers of SPF material are applied, each foam lift (i.e. spray application) shall have adhesion at substrate and foam interfaces.
- SPF insulation shall not exhibit areas that:
 1. Have voids or gaps in the uniformity of the insulation
 2. Are extremely soft or spongy
 3. Show the presence of liquid
 4. Have blistering between lifts
 5. Show differences in coloration of adjacent foam layers
 6. Indicate the presence of other materials between lifts
- SPF insulation shall be installed in conformance with the manufacturer's specifications, recommendations and temperature/humidity limitations.
- Substrates to which SPF insulation is applied shall be secure and free of surface moisture, frost, grease, oils, dirt, dust or other contaminants that would adversely affect SPF adhesion.
- SPF shall be separated from occupied spaces by an approved thermal barrier, such as 0.5 inch gypsum wallboard or other approved material, or show equivalence through testing.
- **SPF shall not be applied directly to recessed lighting fixtures**
- Recessed light fixtures in ceilings insulated with SPF insulation shall be protected from contact with SPF by a combination of one or more of the following methods:
 1. Be covered with a minimum of 1.5 inches of mineral fiber insulation, or
 2. Be enclosed in a box fabricated from 1/4 inch plywood, 18 gauge metal, 3/8inch hard board or gypboard.

Specific Requirements for Wall Insulation (see RA3.5.X.2)

Wall Insulation: All Materials

- Wall stud cavities shall be caulked or foamed to provide a substantially airtight envelope to the outdoors, attic, garage and crawl space.
- All plumbing and wiring penetrations through the top and bottom plates and electrical boxes that penetrate the exterior sheathing shall be sealed.
- All gaps in the air barrier shall be caulked, taped, or sealed with minimally expansive foam.
- Bottom plates of framed and non-framed assemblies shall be sealed to the ground subfloor or slab, and above ground subfloor.
- Insulation shall uniformly fill the cavity side-to-side, top-to-bottom, and front-to-back.

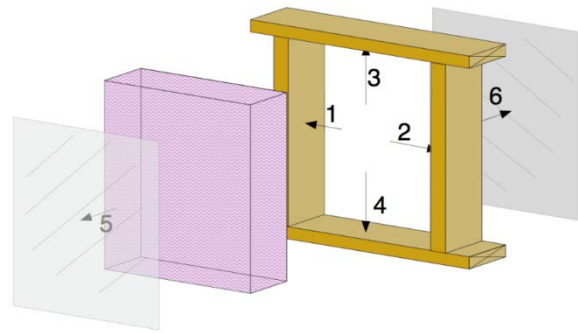

Wall Insulation: Batt and Blanket

- Batt insulation shall fill the cavity by friction fitting, inset or face stapling of flanges of faced batts, or by other support methods as necessary.
- Batt and blanket insulation shall be installed to fill the cavity and be in contact with the sheathing on the back and the wallboard on the front - no gaps or voids.
- Non-standard-width cavities shall be filled with insulation fitted into the space without excessive compression.
- Batt insulation shall be cut to fit snugly around wiring and plumbing, or be split (delaminated) so that one layer can fit behind the wiring or plumbing, and one layer fit in front.

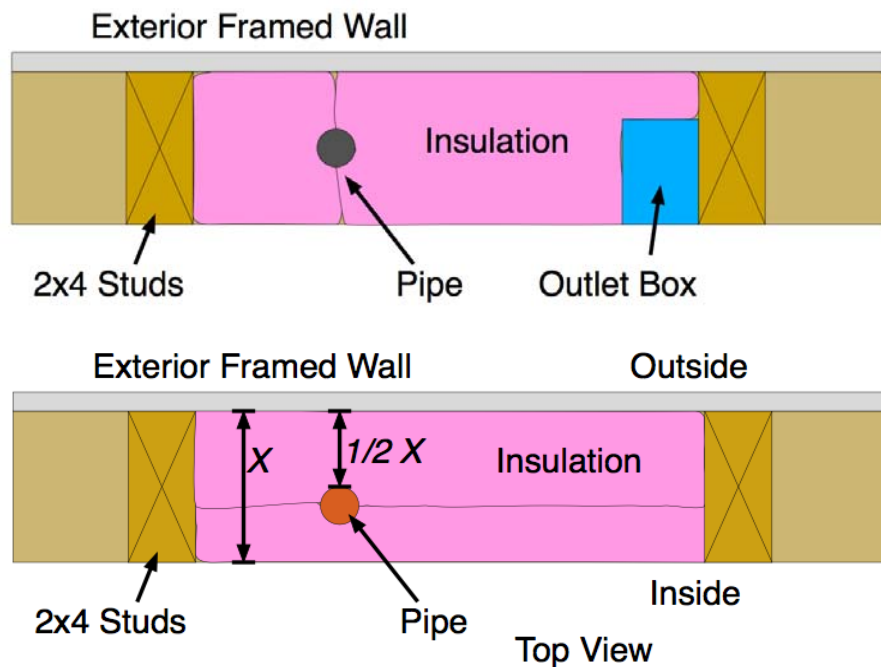

Wall Insulation: Loose Fill

- Loose fill insulation shall be installed to fill the cavity and be in contact with the sheathing on the back and the wallboard on the front - no gaps or voids.
- Loose fill wall insulation shall be installed to fit around wiring, plumbing, and other obstructions.



Wall Insulation: Rigid

- Installation shall uniformly fit across the plane of the wall and **taping** and/or **caulking** of all joints and seams of the insulation shall be maintained to be considered as the air barrier.



Wall Insulation: SPF

- SPF insulation shall be applied to provide an air-tight envelope to the outdoors and between adjoining cavity surfaces of conditioned and unconditioned space, such as the: attic, garage, and crawl space. See **Thermal Specifications** section for more detail.

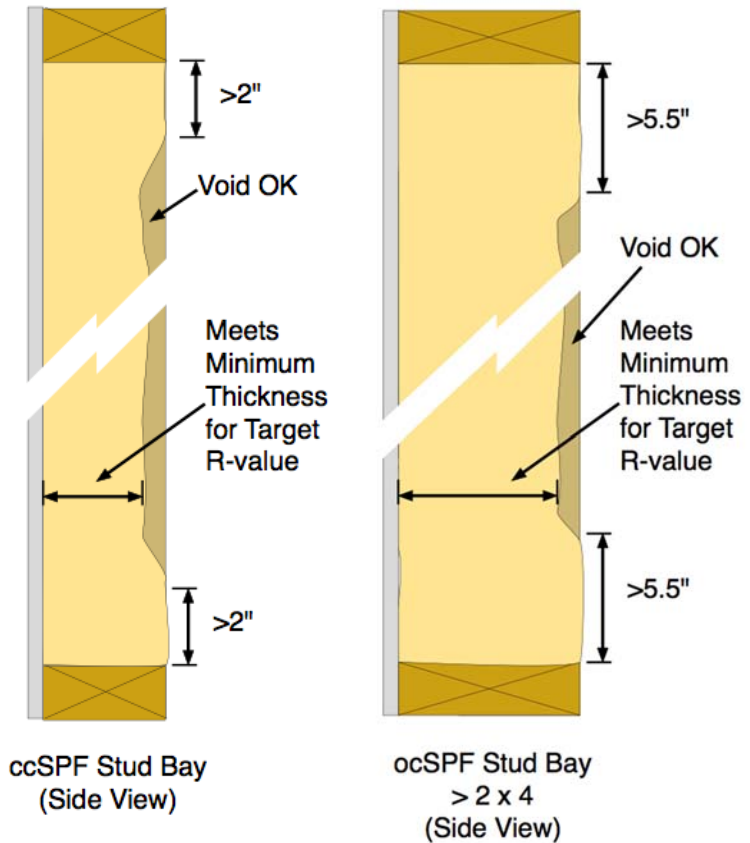

Wall Insulation: Special Situations

Narrow-Framed Cavities (see RA3.5.X.2.1)

- Non-standard width cavities shall be filled with insulation to snugly fit into the space, or with minimally expansive foam sealing material.
- Narrow spaces less than 1 inch in width at windows and door jambs, shall be filled with minimally expansive foam sealing.
- Narrow spaces less than 2 inches in width, such as between studs at building corners, and at the intersection of interior partition walls to exterior walls, shall be filled with insulation snugly fitted in the space, or with minimally expansive foam sealing.



Wall Insulation: Installation Prior to Exterior Sheathing or Lath (see RA3.5.X.2.2)

- Hard to access wall stud cavities, such as corner channels, wall intersections, and behind tub/shower enclosures shall be insulated to the proper R-value. In most cases this can only be completed prior to the installation of the tub/shower enclosure, the exterior sheathing, or the exterior stucco lath.
- An air barrier shall be installed on the inside of the exterior wall(s) directly adjacent to the tub/shower enclosure.

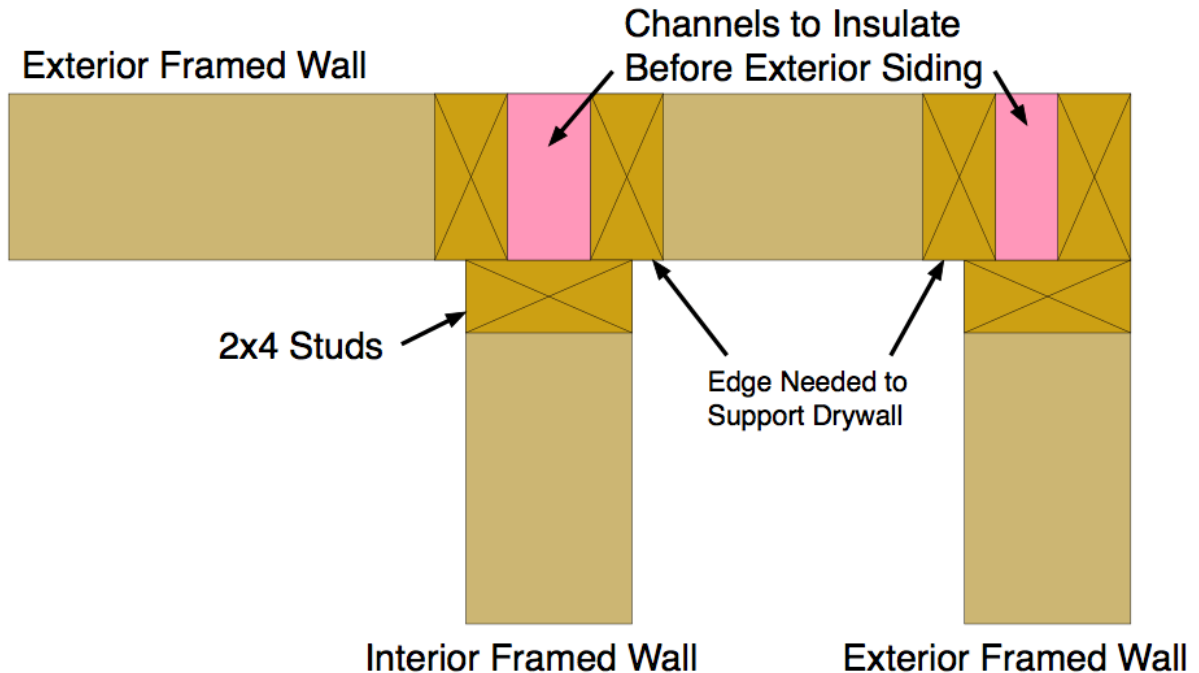

These two photos show bath tubs against exterior walls. When this happens an air barrier must be installed on the inside surface of the wall. The photo on the right shows the air barrier installed. You can also see a metal access door, this door needs to be insulated much the same way an attic access would be insulated. Rigid board insulation would work well here.

Rim Joists (see RA3.5.X.2.4)

- All rim-joists shall be insulated to the same R-value as the adjacent walls.
- The insulation shall be installed without gaps, voids, or compression.

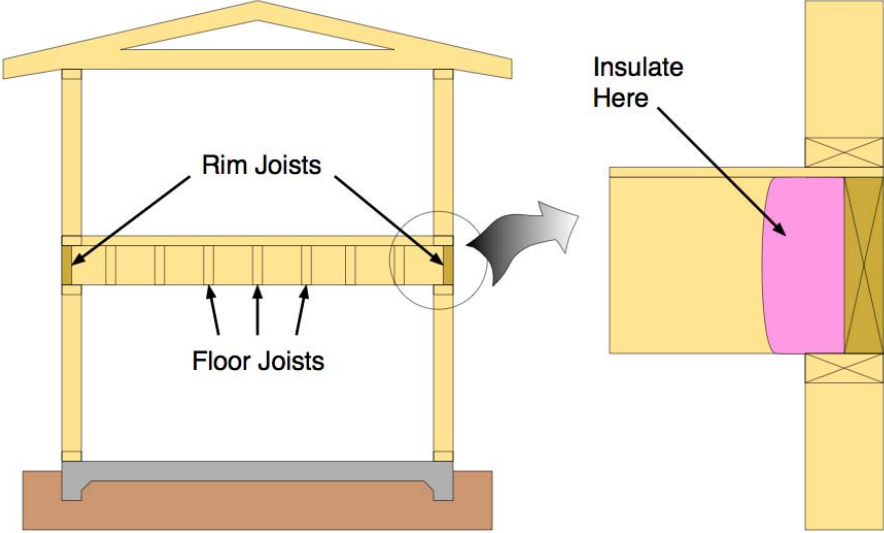

This photo shows rim joists that have been insulated. Unfortunately, the work is too sloppy to meet QII. There is too much compression and there are too many voids.

Kneewalls, Skylight Shafts, and Gable Ends (see RA3.5.X.2.5)

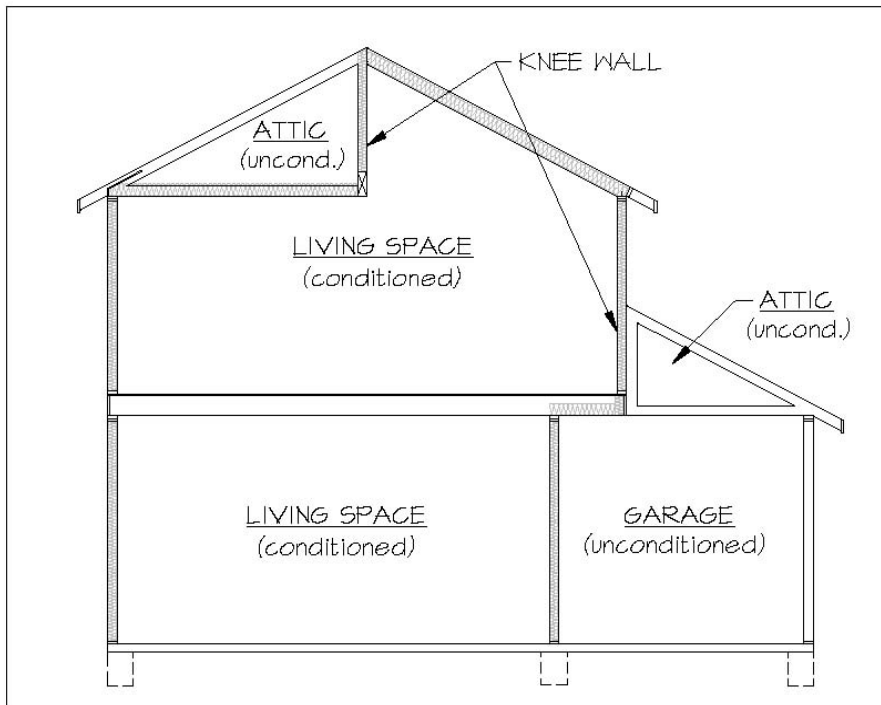

- A kneewall is any vertical wall that separates conditioned space from an unconditioned attic.
- Framing for kneewalls, skylight shafts and gable ends that separate conditioned from unconditioned space shall be insulated to meet or exceed the wall R-value specified on the Certificate of Compliance, and all other required compliance documentation. They can be specifically modeled in a performance run, but must meet or exceed the performance level of how they were modeled. If they are not specifically called out, they must meet the same U-factor as the rest of the walls with similar framing.
- For steel-framed kneewalls, skylight shafts, and gable ends, external surfaces of steel studs shall be covered with insulation unless otherwise specified on the Certificate of Compliance.

- **The exposed attic side of insulation shall be completely covered with rigid board insulation or an air barrier.**

- The house side of the insulation shall be in contact with the drywall or other wall finish.
- The insulation shall be supported so that it will not fall down by either friction fitting to the framing, inset or face stapling of flanges, or using other support such as netting.

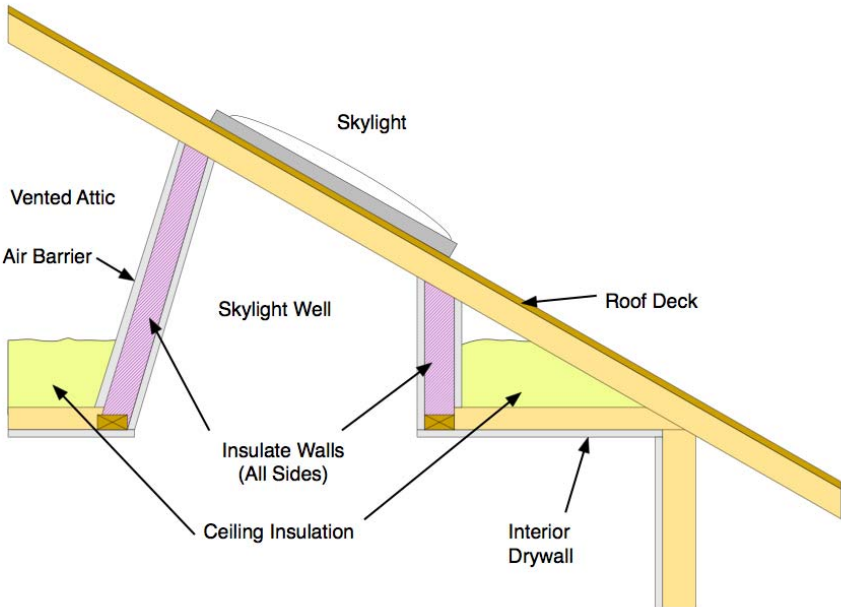

- Insulation for all kneewall and skylight shafts shall be completely enclosed by vertical and horizontal framing, including horizontal plates at top and bottom of the insulation.

- In unvented (conditioned) attics, where insulation is applied directly to the underside of the roof deck, kneewalls, skylight shafts, and gable ends shall be insulated to meet or exceed the wall R-value specified on the Certificate of Compliance, and all other required compliance documentation (only where they separate conditioned and unconditioned space).

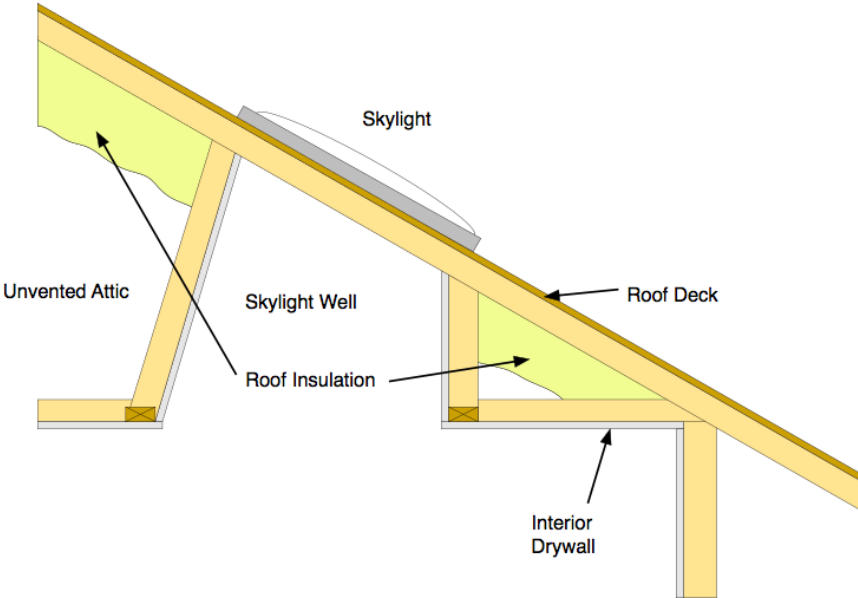

HVAC/Plumbing Closet (see RA3.5.X.2.6)

- Walls of interior closets for HVAC and/or water heating equipment, which require combustion air venting, shall be insulated to the same R-value as the exterior walls as specified in compliance documentation. The fact that these closets exchange air freely with unconditioned space (attic or crawlspace) makes them
- also unconditioned space. They, therefore, must be insulated wherever they are adjacent to conditioned space.
- Sealed combustion furnaces and water heaters with combustion air piped in via PVC pipe need not be installed in a closet that is vented. Similarly for heat pump fan coil units, electric water heaters, hydronic fan coils, and other appliances that do not burn gas. Unvented closets need not be insulated.

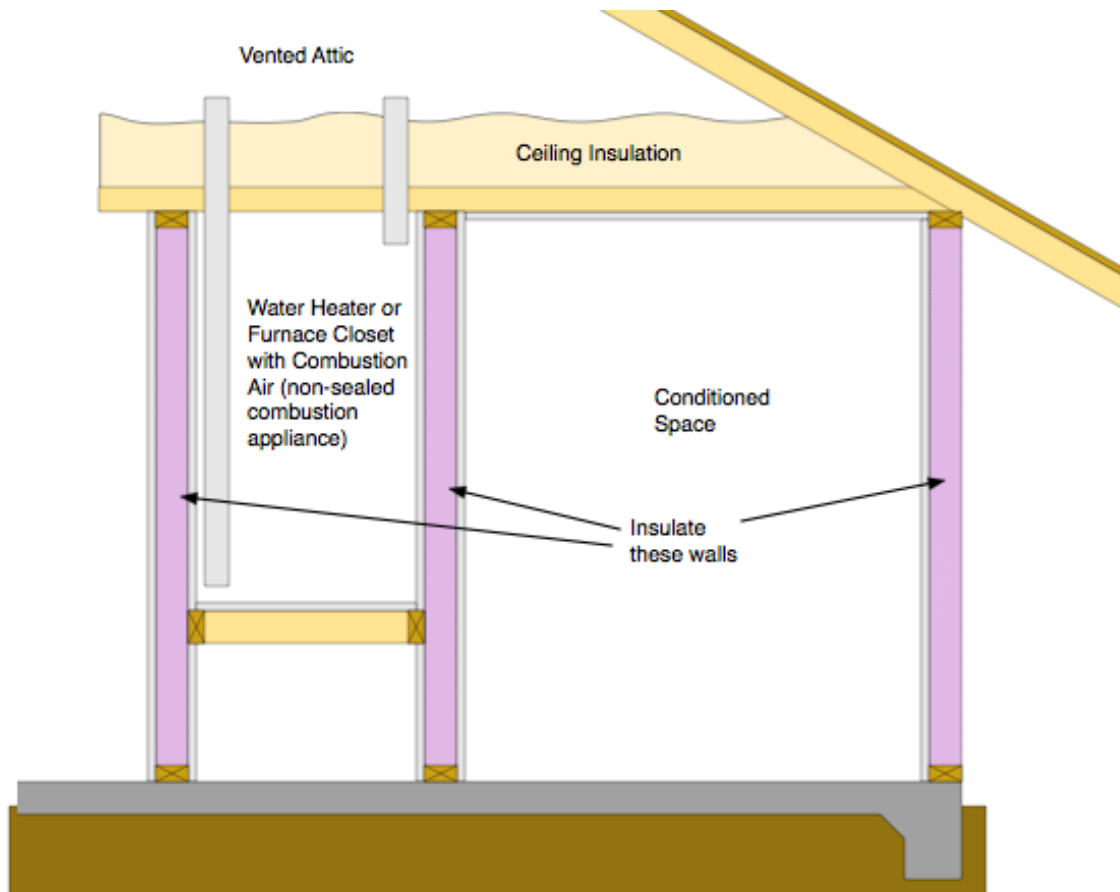

Double Walls and Framed Bump-Outs (see RA3.5.X.2.7)

- Insulation shall fill the entire cavity; or, an additional air barrier shall be installed inside the double wall or bump-out and in contact with the insulation so that the insulation fills the cavity formed with the additional air barrier.
- Entire double walls and framed bump-outs shall be air-tight.

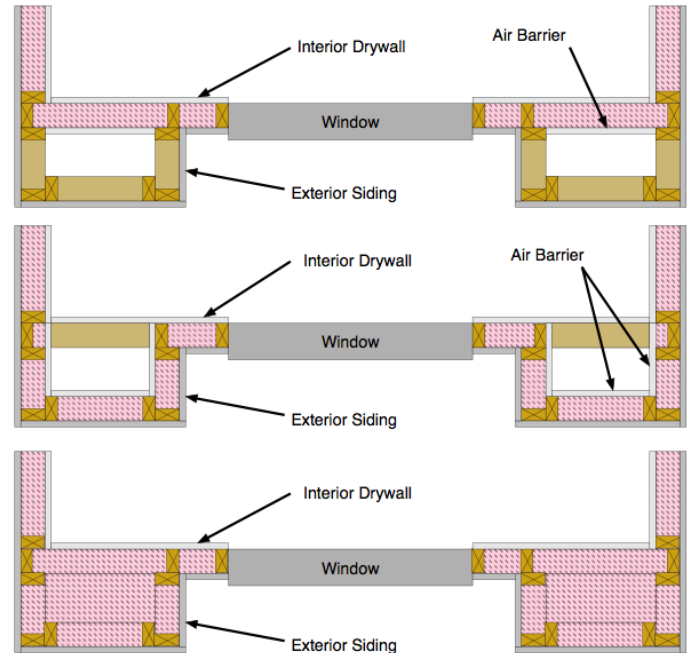

Structural Bracing, Tie-downs, Steel Structural Framing (see RA3.5.X.2.8)

- Framing and bracing used for structural purposes shall be identified on plan documents with diagrams and/or design drawings.
- Insulation shall be installed in a manner that restricts thermal bridging through the structural framing assembly.
- Insulation shall be applied to fully enclose and/or adhere to all sides and ends of structural assembly framing that separate conditioned from unconditioned space.
- The structural portions of assemblies shall be air-tight.

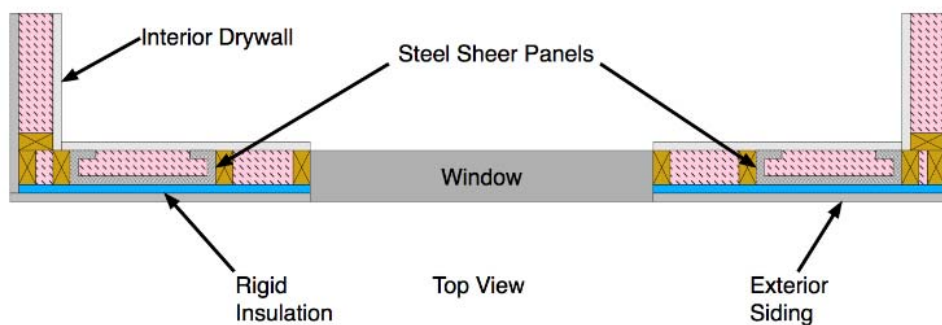

Special Situations--Window and Door Headers (see RA3.5.X.2.9)

- All window and door headers shall be insulated to a minimum of R-3 between the exterior face of the header and inside surface of the finish wall material. Note: The *uninsulated* header is allowed when structural calculations call for a full width header. Option B is recommended due to the difficulty of inspecting the other options.

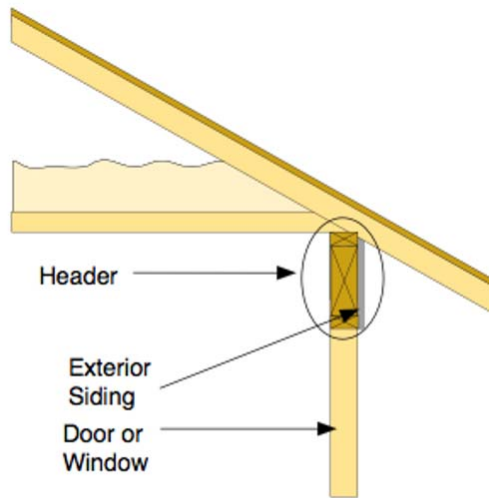

Uninsulated Header

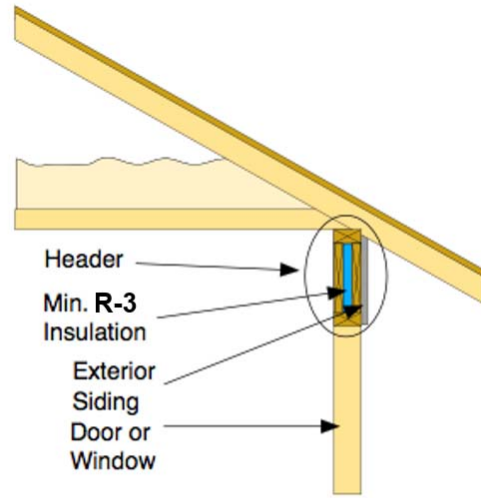

Insulated Header
A

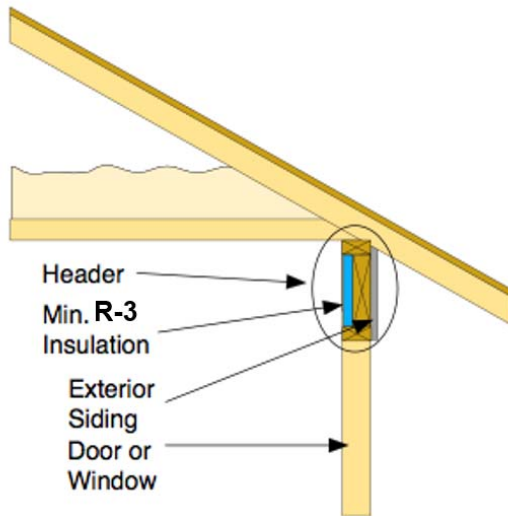

Insulated Header
B

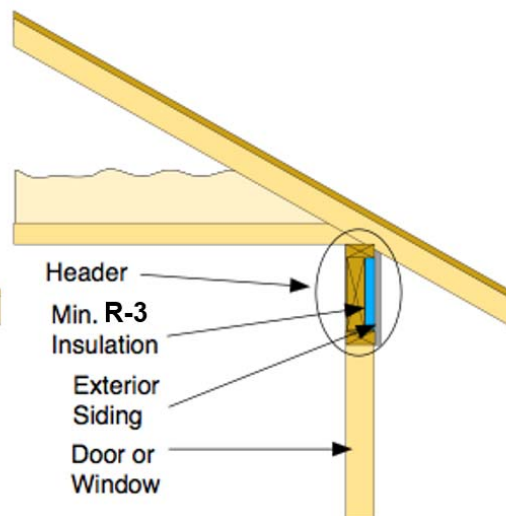

Insulated Header
C

Specific Requirements for Roof/Ceilings (see RA3.5.3.3)

Roof Ceilings: Batt and Blanket

- Batt and blanket insulation shall be correctly sized to fit snugly at the sides and ends.
- Batt and blanket insulation shall be installed to be in contact with the air barrier.
- Where necessary, batt and blanket insulation shall be cut to fit properly - there shall be no gaps, nor shall the insulation be doubled-over or compressed.
- When batt and blanket insulation are cut to fit a non-standard cavity, they shall be snugly fitted to fill the cavity without compression.
- Batt and blanket insulation shall be cut to butt-fit around wiring and plumbing, or be split (delaminated) so that one layer can fit behind the wiring or plumbing, and one layer fit in front.
- Batt and blanket insulation that is thicker than rafter depth shall be installed so that the insulation expands to touch adjoining cavity over each rafter.
- Baffles shall be placed at eaves or soffit vents of vented attics to keep insulation from blocking eave ventilation and prevent air movement under the insulation. The required net free-ventilation shall be maintained.

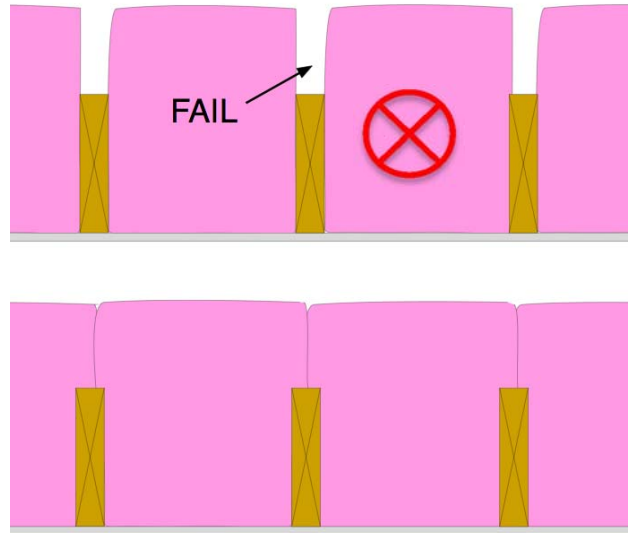

Note: It has been determined that it is virtually impossible to meet the QII requirements with **batts** in an attic ceiling with common roof **trusses** due to the gaps caused by the vertical truss cords.

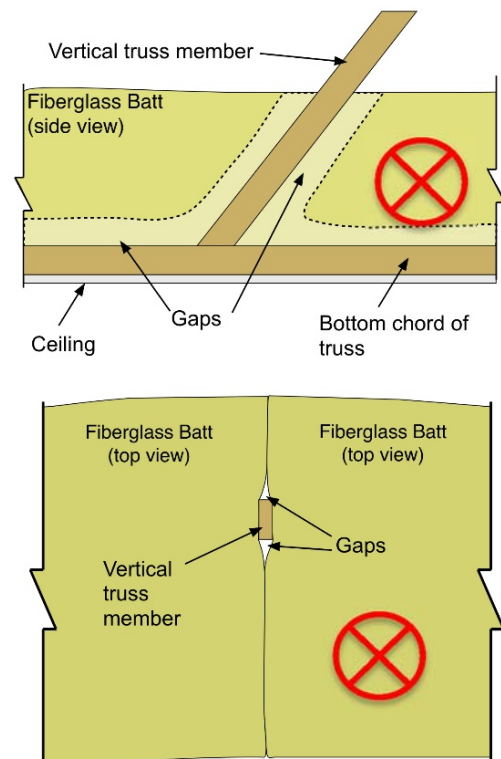

Roof Ceilings: Loose Fill

- Attic rulers appropriate to the material shall be installed and evenly distributed throughout the attic to verify depth: one ruler for every 250 square feet and clearly readable from the attic access. *(Note: The intent of this requirement is to make it as easy as possible for depth to be verified by the HERS Rater and building inspector. If rulers are not clearly visible from the attic access due to architectural constraints, work with the inspector and HERS Rater to come up with an alternative.)* Attic rulers shall be scaled to read inches of insulation and the R-value installed. *(Note that attic rulers are specific to each brand and type of installation and may not be interchanged.)*



- Insulation shall be applied underneath and on both sides of obstructions such as cross-bracing and wiring.
- Insulation shall be kept away from combustion appliance flues in accordance with flue manufacturer's installation instructions or labels on the flue.
- Insulation shall be blown to a uniform thickness throughout the attic with all areas meeting or exceeding the insulation manufacturer's minimum requirements for **depth and weight-per-square-foot**.



Insulation Dam

- The installer shall certify on the Certificate of Installation (CF2R) forms that the manufacturer's minimum weight per- square-foot requirement has been met.
- The HERS Rater shall verify that the manufacturer's minimum weight-per-square-foot requirement has been met for attics insulated with loose-fill insulation. *See “Cookie Cutter Test”.*
- The HERS Rater shall verify that the manufacturer’s minimum insulation thickness has been installed.



- Loose fill insulation shall be applied all the way to the outer edge of the exterior wall's top plate. (Note: This may require an insulation dam where the attic extends over unconditioned space.)

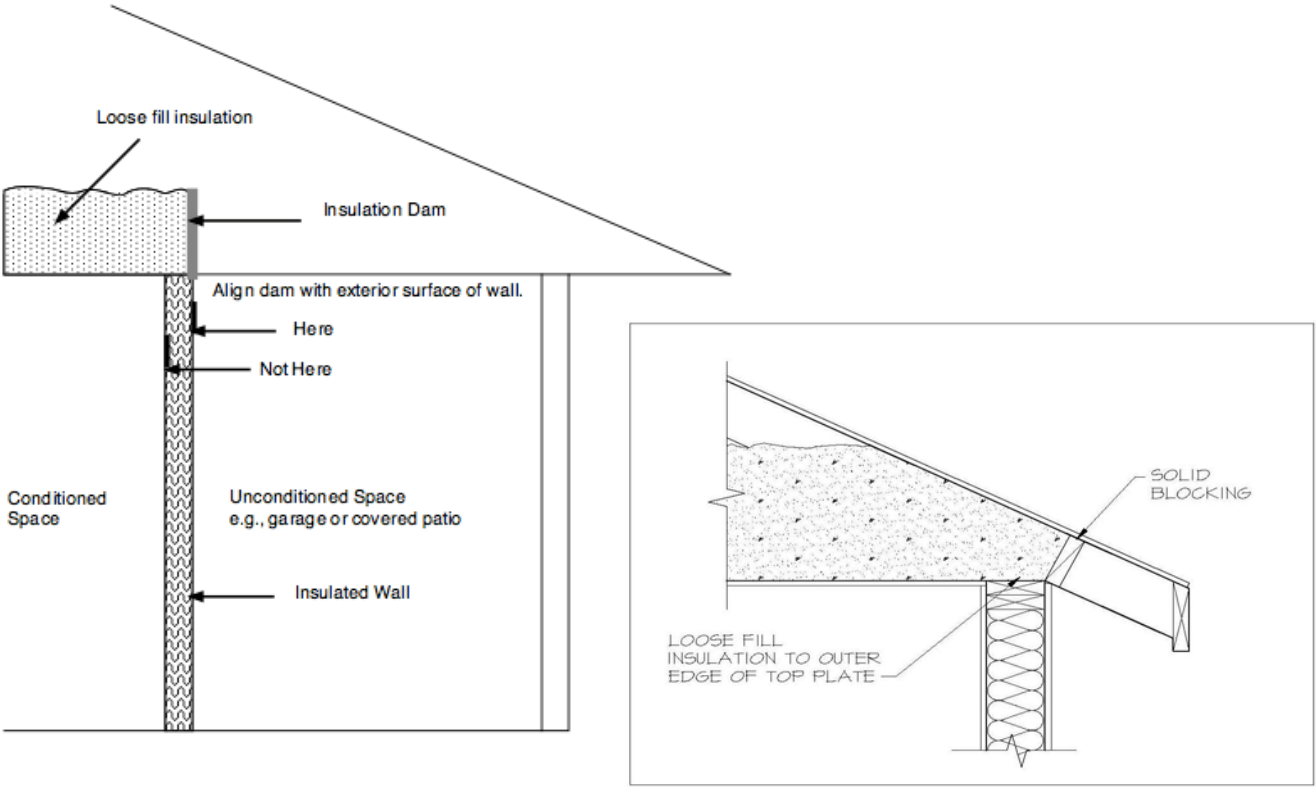

- Because cellulose insulation is relatively dense and settles over time, this verification shall take into account the time that has elapsed since the insulation was installed. Refer to insulation manufacturer's specifications related to settling.

Roof Ceilings: Rigid

- Rigid board insulation installed above the roof deck shall be applied (so that it extends) to the outer edge of the plane of the wall top plate.

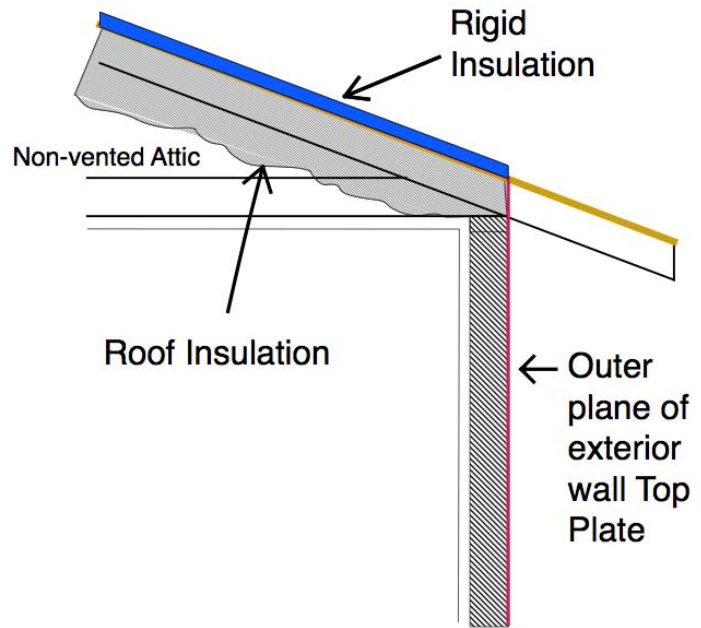

Roof Ceilings: SPF

- SPF insulation shall be applied to fully adhere to the substrate of the ceiling or roof deck.
- SPF insulation shall be applied to fully adhere to the joist and other framing faces to form a complete air seal within the construction cavity.

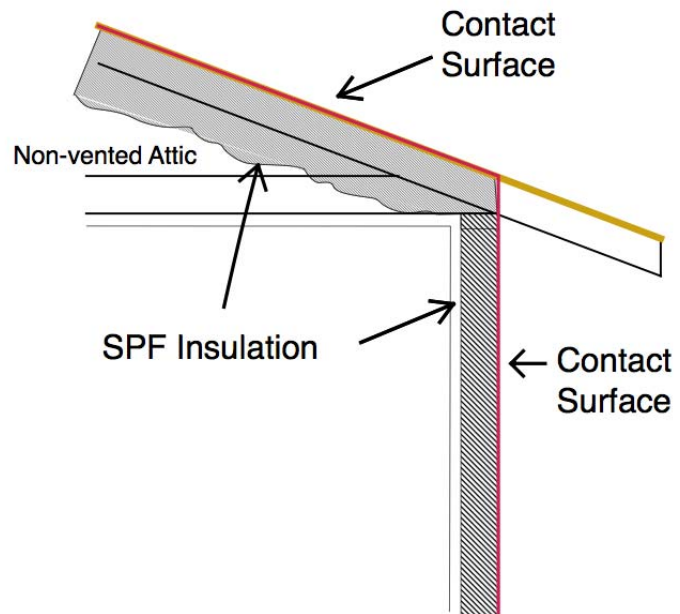

Roof Ceilings: Special Situations

Enclosed Rafter Ceilings (see RA3.5.X.3.1)

- An air space shall be maintained between the insulation and roof sheathing per California Building Code, Sections 1203.2 and R806.3, or as specified by the local building department.
- Facings and insulation shall be kept away from combustion appliance flues in accordance with flue manufacturers' installation instructions or labels on the flue.
- Insulation installed in unvented rafter ceilings or to the underside of unvented roofs with an attic below shall have an R-value conforming to compliance documentation and the air barrier shall be uniform across the transition of roof to wall. The insulation shall be in contact with the air barrier.
- SPF insulation installed in unvented rafter ceilings or to the underside of unvented roofs with an attic below shall have an R-value conforming to compliance documentation and the air barrier shall be uniform across the transition of roof to wall. The insulation shall be in contact with the air barrier.

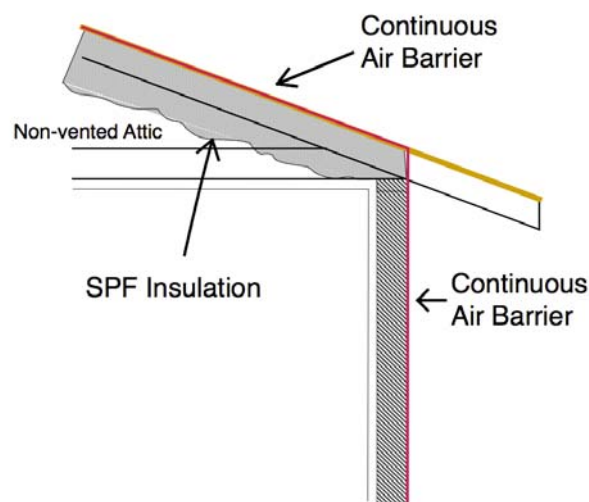
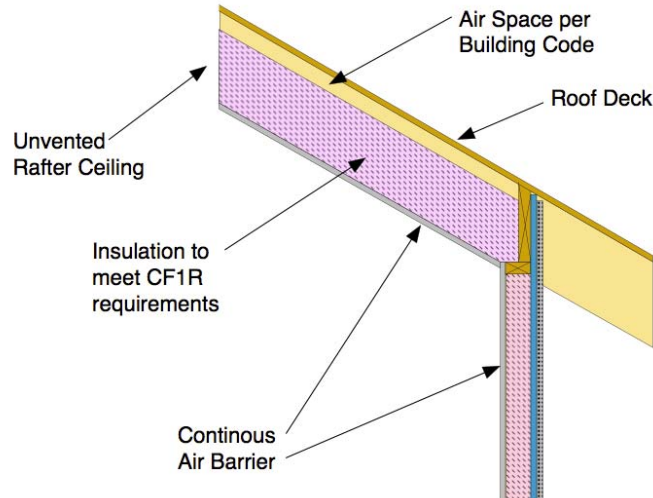

Attics and Cathedral Ceilings (see RA3.5.X.3.2)

- In unvented attics, where insulation is applied directly to the underside of the roof deck, all gable ends shall be insulated to the same R-value as the exterior walls as specified in the compliance documentation.
- In attics where entry is made for the service of utilities, SPF shall be protected from ignition in accordance with CBC, Part 2, Section 2603, and Part 2.5, Section R316 or the SPF assembly must have been tested in accordance with ICC Evaluation Service Acceptance Criteria AC377. (b).

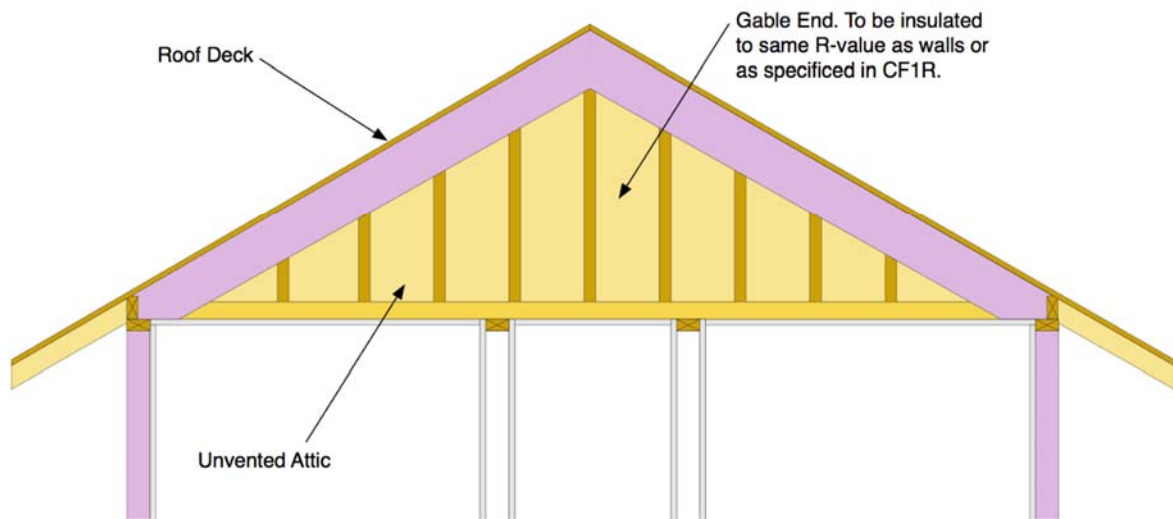

HVAC Platform (see RA3.5.X.3.3)

It is very common for HVAC equipment to be located in the attic, directly above conditioned space. The mechanical code requires easy access to the equipment, this is usually accomplished by building a flat platform out of plywood or OSB. A typical platform size for a single furnace is about 5' x 10'. If it is not near the attic access code also requires a 3' wide "catwalk". The platform and catwalk are usually supported by a reinforced bottom cord of the roof trusses and are often only 6-8" above the ceiling sheetrock. This means that they may interfere with the ceiling insulation. If so, the area under the platform and catwalk needs to be modeled as having a lower R-value than the rest of the ceiling. This will be shown in the Opaque Surfaces section of the CF1R-PRF-01.

- Batt and blanket insulation shall be placed below any platform or cat-walk for HVAC equipment installation and access. (assuming vented attic)
- Batt and blanket insulation shall be installed so that they will be in contact with the air barrier.
- If SPF is used, a minimum of 3 inches of ccSPF insulation or 5.3 inches of ocSPF shall be placed below any platform or cat-walk access ways installed in vented attics for HVAC equipment or other needs.
- The overall assembly R-value shall meet the required R-values specified in the compliance documentation.
- Note: If the platform is taller than the required height of the insulation, it does not need to be in contact with the insulation. The platform is not intended to be an air barrier.

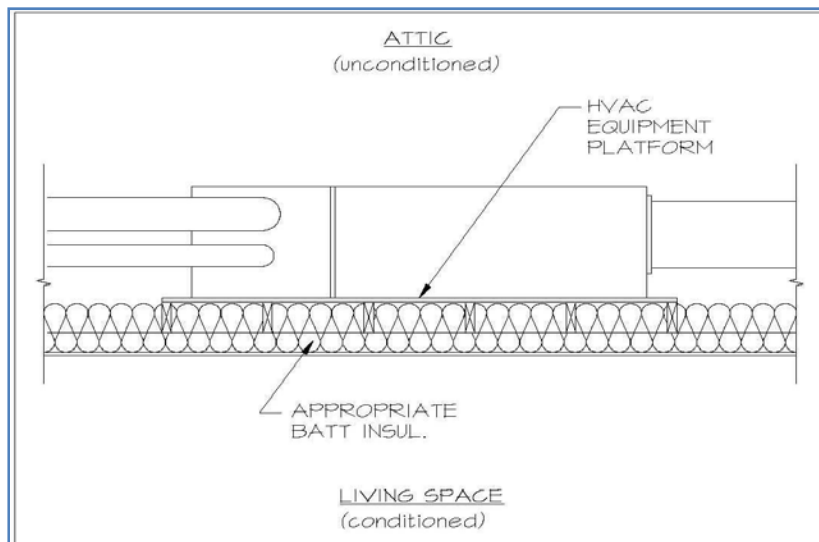

Attic Access (see RA3.5.X.3.4)

- Permanently attach rigid board insulation or batt or blanket insulation with the appropriate R-value to the access door using adhesive or mechanical fastener.
- The bottom of the attic access shall be gasketed to prevent air leakage of conditioned air to the unconditioned attic.
- A minimum of 3 inches of ccSPF or 5.3 inches of ocSPF insulation shall be applied to the access door assuring good adhesion to the door surface.
- Alternatively, permanently attach rigid foam or batt insulation with adhesive or mechanical fastener.
- The overall assembly R-value shall meet the required values specified in the compliance documentation.
- Note: For loose fill insulation, an insulation dam may be required to keep insulation from falling into the access hole and maintaining the minimum insulation depth. Insulation should not be tapered near the access.

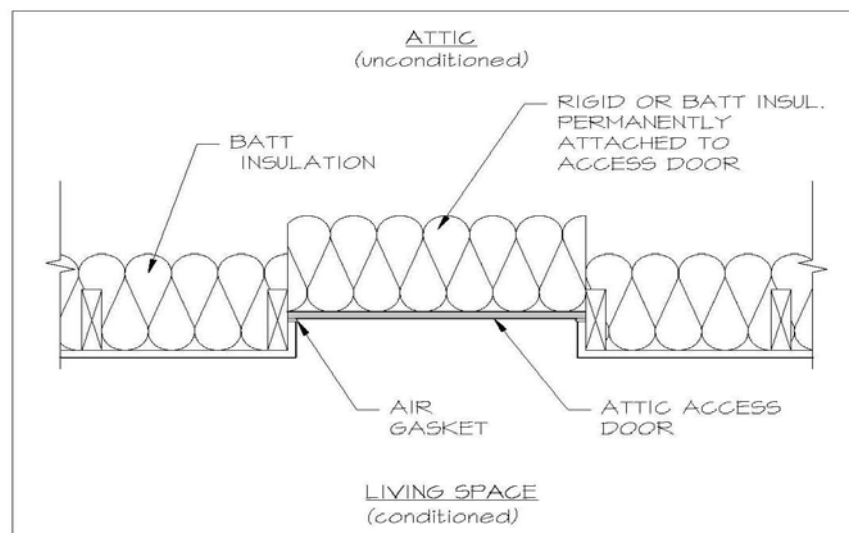

Attic access cover insulated with fiberglass batt. Notice the straps holding insulation in place.



Specific Requirements for Raised Floors (see RA3.5.X.4)

- Batt and blanket insulation shall be correctly sized to fit snugly at the sides and ends.
- Batt and blanket insulation shall be cut to fit properly without gaps.
- Insulation shall not be doubled-over or compressed.
- Batt and blanket insulation shall be in contact with the air barrier - usually the subfloor.
- SPF insulation shall be spray-applied to fully adhere to the bottom side of the floor sheathing.

Note: "TJI" floor joists pose a particular problem for batt insulation. Make sure that the batts are in contact with the subfloor and are full width batts so that they expand into the side pockets created by the I-beam shape of the joists.

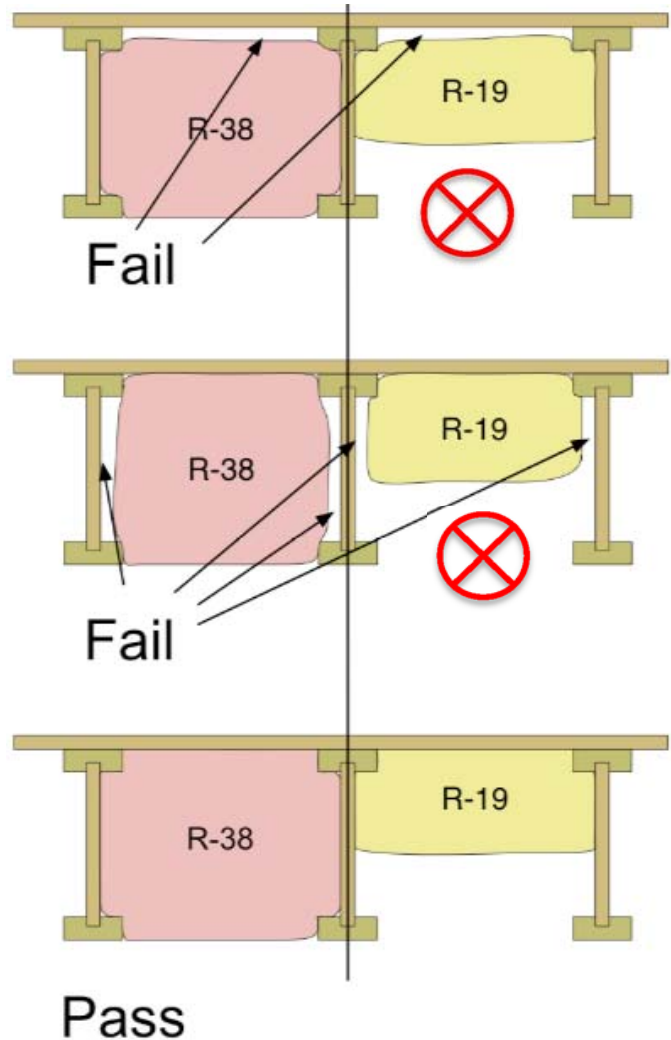

Homes with Conditioned Space Over Garage (see RA3.5.X.4.2)

- The floor over the garage shall be insulated with batt or blanket insulation against the subfloor of the conditioned space.
- The garage and the adjacent conditioned space (house) shall be insulated up to the subfloor.
- All rim and band joists adjoining conditioned space shall be air tight and insulated.

SPF:

- The floor over the garage shall be insulated by spraying SPF insulation to fully adhere to the subfloor of the conditioned space.
- The garage and the adjacent conditioned space (house) shall be insulated up to the subfloor.
- SPF insulation shall cover any gaps between the header and the floor joist.

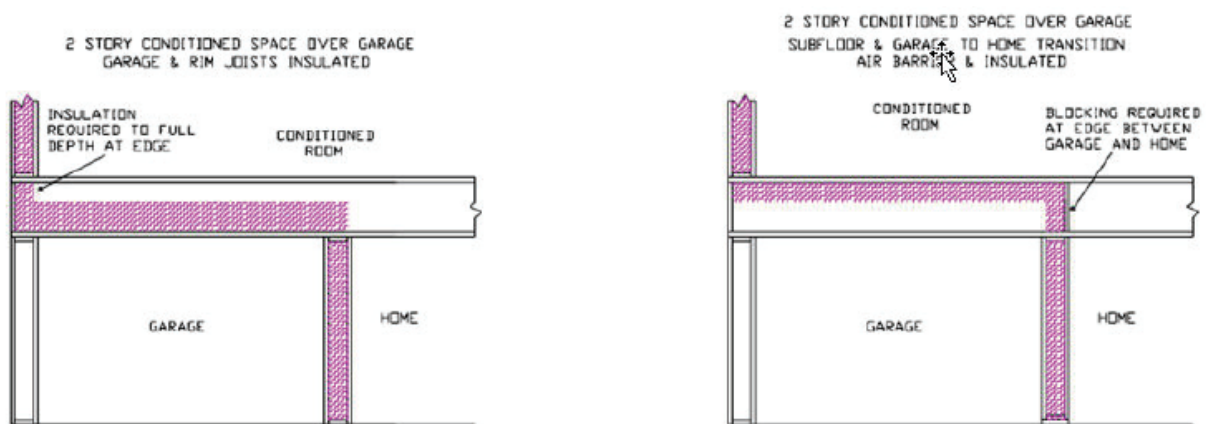
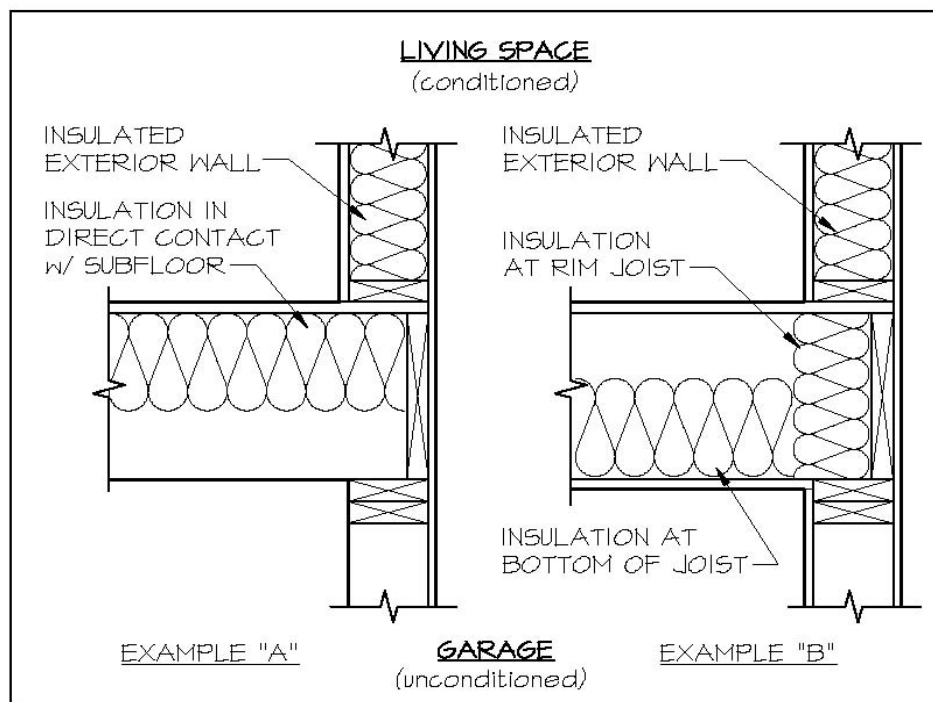

Figure RA3.5-1 Homes with Conditioned Space Over Garage – Batt and Blanket Insulation



Homes with Unconditioned Space Over Garage (see RA3.5.X.4.3)

- The band joist where the garage transitions to an attic above conditioned space shall have an air barrier installed in contact with the edge of the attic insulation.

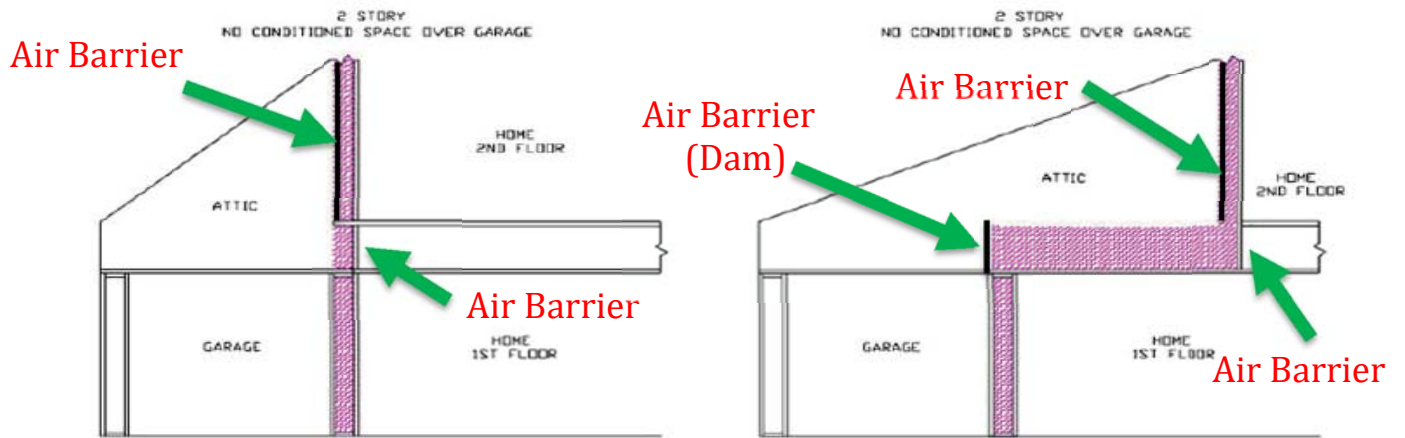

Figure RA3.5-2 Homes with No Conditioned Space Over Garage – Batt and Blanket Insulation



The “Cookie Cutter” Test

- The HERS Rater shall verify that the manufacturer’s minimum weight-per-square-foot requirement has been met for attics insulated with loose-fill mineral-fiber insulation (not cellulose). Verification shall be determined using the methods of the Insulation Contractor’s Association of America (ICAA) Technical Bulletin #17 except that only one sample shall be taken in the area that appears to have the least amount of insulation. The Rater shall record the weight-per-square-foot of the sample on the Certificate of Field Verification (CF-3R) and Diagnostic Testing.

Instructions:

Carefully work the cookie cutter down into the insulation until it sits squarely on the ceiling drywall.

Remove all the insulation and stuff it into a plastic bag.

Weigh the bag.

Divide weight of bag in pounds by the area of the cookie cutter in square feet.

The final value must be greater than the target from the CF2R-ENV-01.

Replace the insulation and fluff it back up as best as you can.



Calculation Worksheet for "Cookie Cutter" Test

Diameter of Cookie Cutter in inches (circle one)	10	→	0.545	Area (sqft)
	12	→	0.785	
	14	→	1.069	
	16	→	1.396	
	13.54	→	1.000	

Measured Weight of Sample (ounces)	<input type="text"/>	ounces
Divide ounces by 16	÷	16
to get lbs	=	lbs
Divide lbs by sqft	÷	<input type="text"/>
to get Measured lbs/sqft	=	lbs/sqft

Enter area below

greater than? If yes, pass. Pass Fail

Target lbs/sqft (from manufacturer)	<input type="text"/>	lbs/sqft
--	----------------------	----------

(Typical targets range from 0.300 to 0.800 lbs/sft, depending on R-value and brand.)

The QII Checklists

The HERS Rater will perform their QII inspections with the help of CF3R checklists. The CF2R forms used by the installers no longer have these checklist items. It is very important that the installer know exactly what the Rater will be looking for. For that reason, we have created these QII checklists. Each item on the checklist is cross referenced with a section of this document for additional detail.

QII Checklist

ENV-22

- ✓ For typical vented attics where the insulation is at the roof deck/ceiling, the air barrier must be verified after the ceiling drywall is installed and before attic insulation is installed.
- ✓ If spray polyurethane foam (SPF) will be used in the attic, this can be considered the air barrier.
- ✓ Soffits and chases must be covered, and chimneys and flues require metal flashing.
- ✓ For buildings with unvented (conditioned) attics, all air sealing requirements appropriate for the roof must be verified.

A. Ceiling Inspection – Vented Attics

(Refer to the definition of a continuous air barrier, air tight, draft stops, hard covers, and the sections “The Importance of Defining the Thermal Boundary” and “Special Requirements for Sealing Against Air Movement” in the CalCERTS QII Handbook.)

- 01 There is a continuous air barrier at the ceiling level. All openings into walls, drops, chases, or double walls are sealed.
- 02 Chimneys and flues require sheet metal flashing. The flashing shall be sealed to the chimney/flue with fire rated caulk. The flashing shall be sealed to the surrounding framing.
- 03 All penetrations through the top plate of interior and exterior walls are sealed.
- 04 Electrical boxes, fire alarm boxes, and fire sprinklers cut into ceilings are sealed to the surrounding drywall. If it is not possible to seal the fixture directly, a secondary air barrier shall be created around the fixture.
- 05 All installed recessed light fixtures that penetrate the ceiling to unconditioned space are rated to be Insulation Contact and Airtight (IC and AT) which allows direct contact with insulation. The housing is sealed to the drywall.
- 06 Exhaust fan housing is sealed to the surrounding drywall and all holes and seams in the housing are sealed.
- 07 All soffits and chases are covered with a hard cover that is sealed to the framing with caulk or foam.
- 08 Double walls that open to the attic are covered and the cover is sealed to the framing.
- 09 Attic access forms an airtight seal between conditioned space and unconditioned space. Vertical attic access requires mechanical compression using screws or latches.
- 10 Knee walls require solid and sealed blocking at the bottom, top, left, and right sides.
When the knee wall is placed on top of a subfloor the open cavity between the subfloor and the ceiling below is sealed.
- 11 Where HVAC ducts travel down a chase, the chase is sealed at the ceiling level.
- 12 HVAC boots that penetrate the ceiling are sealed to the surrounding drywall.
- 13 All top plates of interior and exterior walls are sealed to drywall.
- 14 Attic access must be surrounded with a dam at least the same depth as the insulation to prevent loss of ceiling insulation.
- 15 There must be a dam placed at the exterior edge of all knee walls and at all edges of insulation to stop air movement through the insulation.

B. Roof Inspection – Unvented attics

- 01 There is a continuous air barrier at the roof deck and gable ends.
- 02 Chimneys and flues require sheet metal flashing at the roof deck. The flashing is sealed to the chimney/flue with fire rated caulk. The flashing is sealed to the surrounding framing.
- 03 All penetrations for plumbing, electrical, etc. in the roof deck and gable ends are sealed.

ENV-23

A. Quality Insulation Installation (QII) Preparation for Insulation

- 01 Air barrier installation and preparation for insulation was done and verified at framing stage prior to insulation being installed. Where applicable, CF3R-ENV21 and 22 compliance documents have been signed off.
- 02 All structural framing areas shall be insulated in a manner that resists thermal bridging of the assembly separating conditioned from unconditioned space. Structural bracing, tie-downs, and framing of steel, or specialized framing used to meet structural requirements of the CBC are allowed and must be insulated. These areas shall be called out on the building plans with diagrams and/or specific design drawings indicating the R-value of insulation and fastening method to be used. It is recommended that spray foam be used.
- 03 All insulation was installed to the manufactures insulation installation instructions.

B. Quality of All Installed Insulation

- 01 Installed insulation R-values are the same or greater than specified on the CF1R.
- 02 No gaps or voids between the insulation and framing.
- 03 Gaps between studs shall be filled with insulation.

- 04 Batt - ensure the ends are cut so there are no gaps.
- 05 Batt - insulation is cut around obstructions like electrical boxes and no gaps exist.
- 06 Batt - insulation is not compressed (no stuffing of the insulation into the cavity).
- 07 Batt insulation is delaminated around all plumbing and electrical lines in ceilings, walls and floors.
- 08 An air barrier is installed at all exposed edge faces of batt, loose fill and SFP insulation.
- 09 Loose-fill insulation installed to the minimum installed weight per ft² per the manufacturer's labeled R-value specification.
- 10 SPF insulation shall be spray-applied to fully adhere to structural assembly framing, floor and ceiling joists, and other framing surfaces within the construction cavity.
- 11 SPF - with multiple layers applied, each foam lift (i.e. spray application) adheres to the substrate and foam interfaces.
- 12 SPF - if values other than R-5.8 per inch for closed-cell SPF (ccSPF) and R-3.6 per inch for open-cell SFP (ocSPF) are used, the ICC Evaluation Service Report (ESR) number (e.g. ESR-xxxx) will be documented on the CF2R-ENV-03.
- 13 ccSPF - in areas where an air barrier is required the foam is at least 2 inches thick.
- 14 ocSPF depressions in the foam insulation surface are not greater than 1-inch of the required thickness provided these depressions do not exceed 10% of the surface area being insulated.
- 15 ocSPF insulation completely fills cavities of 2x4 inch framing or less.
- 16 ocSPF cavities greater than 2x4 inch framing are filled to the thickness that meets the required R-value used for compliance.
- 17 SPF installed as an air barrier is sprayed at a minimum of 5.5 inches in thickness for open cell and 2.0 inches for closed cell.
- 18 The insulation installer provided a CF2R-ENV-03. Labels or specification/data sheets are attached to the CF2R-ENV-03 for each insulating material. The material datasheet for the installed material meets the performance specifications of the required R-Values. Blown in material also includes insulation material bag labels or coverage charts.

C. Ceiling/Roof Insulation

- 01 Insulation extends to the outside edge of the exterior top plates and is flush against any ventilation dams/baffles.
- 02 Insulation is in direct contact with ceiling so there are no gaps between the ceiling and the insulation.
- 03 Chimneys and flues (except for zero clearance) require sheet metal collar around the stack. The collar must be at least as tall as the depth of the insulation. The collar shall be 1" from the chimney/flue for double wall vent, and 6" from the chimney/flue for single wall vent" unless manufacturer requires otherwise. The collar must be sealed to the ceiling with high temperature sealant to prevent air leakage. The insulation is in contact with the sheet metal collar.
- 04 Required eave ventilation shall not be obstructed - the net free-ventilation area of the eave vent is maintained
- 05 Eave vent baffles are installed to prevent air movement under, or into, the ceiling insulation.
- 06 Recessed downlights are covered with insulation, if not using SPF. If they are not covered to the same depth as required by the CF1R for ceiling insulation then an area weighted calculation is required. Recessed downlights are AT and IC rated.
- 07 SPF insulation shall not be applied directly to recessed lighting fixtures. Recessed downlights where SPF insulation is installed shall:
 - (a) be covered with a minimum of 1.5 inches of mineral fiber insulation, or
 - (b) be enclosed in a box fabricated from 1/4 inch plywood, 18 gauge metal, 3/8 inch hard board or gypboard. Hard board or gypboard do not cause a recessed downlights to meet the zero clearance insulation contact requirements.
- 08 Walkways and mechanical platforms are insulated to the same R-value as required by the CF1R for ceiling insulation. If not an area weighted calculation is completed and turned in with this compliance document.
- 09 Soffits, chasses, drops have a sealed hard cover and the insulation is in direct contact with the hard cover.
- 10 Knee walls – an air dam the full depth of the ceiling insulation is added to the exterior edge of the knee wall so the ceiling insulation overlaps the knee wall to the full depth of the ceiling insulation.
- 11 Attic access doors are insulated to the same R-value required by the CF1R for roof insulation and the insulation is permanently attached using adhesive or mechanical fasteners. Preferred method is rigid insulation.
- 12 Attic access forms airtight seal from conditioned space to unconditioned space. Vertical attic access requires mechanical compression using screws, or latches.
- 13 Attic access must have a dam around the access to at least the same depth as the insulation.
- 14 Insulation batts must be cut to fit around cross bracings and truss webs.
- 15 Attic rulers appropriate to the material are installed and evenly distributed throughout the attic to verify Depth (one ruler for every 250 ft²) The rulers are clearly readable from the attic access and scaled to read inches of insulation and the R-value installed.
- 16 Loose-fill and SPF insulation - a HERS Rater shall measure the installed thickness (include low and high areas) and density of insulation in at least 6 random locations on walls, roof/ceilings and floors to ensure minimum thickness levels and the installed density meets the R-value specified on the Certificate of Compliance, and are consistent with the manufacturer's coverage chart.
- 17 Steel-framed kneewalls, skylight shafts, and gable ends, external surfaces of steel studs are covered with insulation

How to Read the Insulation Requirements on a CF1R-PRF-01

The CF1R-PRF-01-E (CF1R) lists the energy features required to meet the Title 24 Energy Code. It will include areas and orientations of all the surfaces of the home that impact the home's energy use: windows, skylights walls, doors, floors, ceilings, attics and roof. Different walls with different thermal properties (2x4 walls with R-15 vs 2x6 walls with R-21) will be modeled differently. The following steps will help you determine the minimum insulation required in all of the surfaces.

1. Make sure the CF1R is registered.

- a. It should have a CalCERTS logo watermark (a light image of the CalCERTS logo behind the text of the document on every page).
- b. It should also have a certificate number at the bottom of each page of the format 217-X#####X-###-###-#####-#####" where "#" is a numeral and "X" is a letter.

2. Make sure the CF1R is current.

- a. Contact the "Responsible Designer" who signed the last page.
- b. Confirm with them that the registration date/time at the bottom of each page is the most current and that it is the one you should be bidding from. Ask if the project is participating in any above-code requirements. It is possible that the requirements might be different.

3. Confirm details in "General Information Section" – first section on first page.

4. Determine if QII is required.

- a. Find the "HERS Feature Summary" section, usually near the top of the second or third page.
- b. Look for the statement "**High quality insulation installation (QII)**". If it is on the list, QII is required.

HERS FEATURE SUMMARY	
The following is a summary of the features that must be field-verified by a certified HERS Rater as a condition for meeting the modeled energy performance for this computer analysis. Additional detail is provided in the building components tables below.	
Building-level Verifications: <ul style="list-style-type: none">• High quality insulation installation (QII) ←• IAQ mechanical ventilation	<h1>SAMPLE</h1>
Cooling System Verifications: <ul style="list-style-type: none">• Verified EER• Verified SEER• Fan Efficacy Watts/CFM	
HVAC Distribution System Verifications: <ul style="list-style-type: none">• Duct Sealing• Low-leakage Air Handling Unit	
Domestic Hot Water System Verifications: <ul style="list-style-type: none">• -- None --	

- c. If QII is required,
 - i. Evaluate plans very carefully. Look for unclear parts of thermal boundary. (knee walls, hard covers, bump outs, fire places, etc.) These are common causes of fails.
 - ii. Define responsibilities for trades. (air barriers, blocking, attic vents, sealing around fans, electrical boxes, insulated headers, etc.)
 - iii. Contact the HERS Rater for the project as soon as possible. Ask them for checklists, other informational materials.
 - iv. Meet at project early to discuss details of the QII requirements.
 - v. Learn to use CalCERTS registry.

5. **Find the “Opaque Surfaces” section.** This will show the walls, floors, and ceilings.
 - a. Column 01 is the name of each surface being modeled. This is just a text field and has no impact on the simulation. Do not trust names like “R-15 Wall”. The actual R-value needs to be verified in the “Opaque Surfaces Construction” section.
 - b. Column 02 is the name of the “zone” that the surface is adjacent to. If it shows two zones, such as “Main Conditioned Space>>>Garage”, this means that the surface separates these two zones. Even though the garage may have been modeled, it is not conditioned space and it would be very unusual to require insulation in the exterior walls of the garage. The surfaces that just say “garage” can usually be ignored.
 - c. Column 03 is a construction assembly name that references a later section in the CF1R, “Opaque Surface Constructions” where there will be a detailed description of the construction of the surface (discussed below).
 - d. Column 04 is the azimuth (direction) of the surface. 0=north, 90=east, 180=south, 270=west.
 - e. Column 05 describes the side of the house that the surface is on.
 - f. Column 06 is the gross area of the surface (includes windows and doors).
 - g. Column 07 is the window and door area in that surface. Subtract column 07 from column 06 to get the net surface area (the area to be insulated). If any of these numbers deviate from your take-offs using the plans, you should contact the “Documentation Author” who signed the last page of the CF1R.
 - h. Column 08 is the tilt of the surface. 0=horizontal, 90=vertical.

OPAQUE SURFACES							
01	02	03	04	05	06	07	08
Name	Zone	Construction	Azimuth	Orientation	Gross Area (ft ²)	Window & Door Area (ft ²)	Tilt (deg)
Front Wall 1	Main Conditioned Space	Construction Assembly 3	0	Front	160	60	90
Left Wall	Main Conditioned Space	Construction Assembly 3	90	Left	472	78	90
Back Wall 1	Main Conditioned Space				450	175	90
Right Wall 1	Main Conditioned Space				612	83.5	90
Front Interior Wall	Main Conditioned Space>>Garage				290	21.5	
Left Interior Wall 1	Main Conditioned Space>>Garage				137	0	
Ceiling (below attic) 1	Main Conditioned Space				2600		
Front Exterior Wall 1	Garage	Construction Assembly 4	0	Front	290	168	90
Left Exterior Wall 1	Garage	Construction Assembly 7	90	Left	185	21.5	90
Ceiling (below attic) 2	Garage	Construction Assembly 8			836		

6. **Find the “Attic” section.** This will tell you if the attic is ventilated or not and if ventilated, whether it is a “high performance attic (HPA)” or not. HPAs are ventilated attics with insulation at the attic floor (ceiling of house) **and** either above or below the roof deck.
 - a. Column 01 is the Attic surface name. This is just a text field. Do not trust any R-values shown in the name. They should be confirmed in the “Opaque Surfaces Construction” section.
 - b. Column 02 is a construction assembly name that references a later section in the CF1R, “Opaque Surface Constructions” where there will be a detailed description of the construction of the surface (discussed below).
 - c. Column 03 will tell you if it is ventilated or not.

d. Columns 04-08 describe the roof and any cool roof products or radiant barrier.

ATTIC							
01	02	03	04	05	06	07	08
Name	Construction	Type	Roof Rise	Roof Reflectance	Roof Emittance	Radiant Barrier	Cool Roof
Attic	Construction Assembly 5	Ventilated	5			No	No

SAMPLE

7. Find the “Opaque Surface Constructions” section. This is where the details of the construction assemblies can be found.
- Column 01 are the construction assembly names that were referenced in column 03 of the Opaque Surfaces section and column 02 of the Attic section. Again, names are always just text fields typed in by the documentation author. Do not trust R-values that appear in this column.
 - Column 02 is the surface type
 - Column 03 is the construction type.
 - Column 04 describes the framing of the surface.
 - Column 05 describes the R-value of the insulation installed in the surface cavity (between framing members).
 - Column 06 describes the overall assembly U-factor. This is actually the most important number in terms of performance and compliance. It accounts for the entire assembly. If the U-factor is not met, it doesn’t matter what R-value is installed.
 - Column 07 describes the assembly layers. Look for insulation called “continuous” or “sheathing”. This will be things like R-4 rigid polystyrene insulation installed on the exterior of the framing for 1-coat stucco systems.

OPAQUE SURFACE CONSTRUCTIONS						
01	02	03	04	05	06	07
Construction Name	Surface Type	Construction Type	Framing	Total Cavity R-value	Winter Design U-value	Assembly Layers
Construction Assembly 2	Ceilings (below attic)	Wood Framed Ceiling	2x4 Bottom Chord of Truss @ 24 in. O.C.	R 38	0.025	<ul style="list-style-type: none"> • Inside Finish: Gypsum Board • Cavity / Frame: R-9.1 / 2x4 Btm Chrd • Over Ceiling Joists: R-28.9 insul.
Construction Assembly 3	Exterior Walls	Wood Framed Wall	2x6 @ 24 in. O.C.	R 24	0.045	<ul style="list-style-type: none"> • Inside Finish: Gypsum Board • Cavity / Frame: R-24 / 2x6 • Sheathing / Insulation: Wood Siding/sheathing/decking • Exterior Finish: R4 Synthetic Stucco
Construction Assembly 5	Attic Roofs	Wood Framed Ceiling	2x4 Top Chord of Roof Truss @ 24 in. O.C.	none	0.478	<ul style="list-style-type: none"> • Inside Finish: Gypsum Board • Cavity / Frame: no insul. / 2x4 Top Chrd • Roof Deck: Wood Siding/sheathing/decking • Roofing: 10 PSF (RoofTile)
Construction Assembly 6	Interior Walls	Wood Fr			0.058	<ul style="list-style-type: none"> • Inside Finish: Gypsum Board • Cavity / Frame: R-24 / 2x6 • Other Side Finish: Gypsum Board
Construction Assembly 7	Exterior Walls	Wood Fr			0.361	<ul style="list-style-type: none"> • Inside Finish: Gypsum Board • Cavity / Frame: no insul. / 2x4 • Exterior Finish: 3 Coat Stucco
Construction Assembly 8	Ceilings (below attic)	Wood Fra			0.481	<ul style="list-style-type: none"> • Inside Finish: Gypsum Board • Cavity / Frame: no insul. / 2x4 Btm Chrd

SAMPLE

8. Find the “Slab Floor” section. Check column 05 of the for slab edge insulation. It’s not very common, but if it’s modeled, it must be installed.
9. The “Building Envelope – HERS Verification Section” will reiterate that QII is required.

Blank Page



CalCERTS, Inc.
31 Natoma Street, suite 120
Folsom
CA 95630

916-985-3400
field@calcerts.com